

Technical Description

Evolution Series XPAND

Multi Service Radio Link System, 5 - 38 GHz

This page is intentionally left blank

The information in this documentation is subject to change without notice and describes only the product defined in the introduction of this documentation. This documentation is intended for the use of Nera's customers only for the purposes of the agreement under which the documentation is submitted, and no part of it may be reproduced or transmitted in any form or means without the prior written permission of Nera.

The information or statements given in this documentation concerning the suitability, capacity, or performance of the mentioned hardware or software products cannot be considered binding but shall be defined in the agreement made between Nera and the customer. However, Nera has made all reasonable efforts to ensure that the instructions contained in the documentation are adequate and free of material errors and omissions. Nera will, if necessary, explain issues that may not be covered by the documentation. Nera's liability for any errors in the documentation is limited to the documentary correction of errors.

NERA WILL NOT BE RESPONSIBLE IN ANY EVENT FOR ERRORS IN THIS DOCUMENTATION OR FOR ANY DAMAGES, INCIDENTAL OR CONSEQUENTIAL (INCLUDING MONETARY LOSSES), that might arise from the use of this documentation or the information in it. This documentation and the product it describes are considered protected by copyright according to the applicable laws.

NERA logo is a registered trademark of Nera ASA. Other product names mentioned in this documentation may be trademarks of their respective companies, and they are mentioned for identification purposes only.

Copyright © Nera 2006. All rights reserved.

Document history

Revision	Date	Summary of changes
Rev A	24.feb.2006	First Release
Rev B	28.mar.2006	Added info about PDH X-connect. Updated channel plan info. Removed low priority traffic. Corrected editorial errors
Rev C	23.june.2006	4.2.7 Environmental conditions updated. 11 GHz Output Power updated

Contents	Page
1. INTRODUCTION	7
1.1. FEATURES	9
1.2. NETWORK APPLICATIONS	10
2. SYSTEM DESCRIPTION	13
2.1. IFU WITH PDH X-CONNECT	13
2.2. OUTDOOR UNIT (ODU) DESCRIPTION	16
2.3. IFU UNIT DESCRIPTIONS	16
2.3.1. Supervisory Unit	16
2.3.2. Radio Interface Unit – RIU	16
2.3.3. Line Interface Unit – LIU	16
2.3.4. SDH/SONET Digital X-Connect Unit	16
2.3.5. Alarm and Control Unit	17
2.3.6. 64 kb/s Serial Channel Unit	17
2.3.7. EOW Unit (Service channel)	17
2.3.8. Fan Unit	17
2.3.9. Power Supply Unit	17
3. SYSTEM CONFIGURATIONS	18
3.1. 1+0 SYSTEM	18
3.2. 1+1 HSB / 1+1 FD SYSTEM	19
3.3. SPACE DIVERSITY/DUAL ANTENNA SYSTEM	19
3.4. NODE CONFIGURATION	20
4. EQUIPMENT CHARACTERISTICS	21
4.1. FREQUENCY BANDS	21
4.2. GENERAL EQUIPMENT SPECIFICATIONS	24
4.2.1. Equipment Reference Points	24
4.2.2. ETSI Equipment Class	24
4.2.3. Electromagnetic Compatibility Conditions (EMC)	24
4.2.4. Safety conditions	24
4.2.5. RoHS and WEEE compliance	24
4.2.6. Equipment Type Approval	24
4.2.7. Environmental conditions	25
4.3. MECHANICAL CHARACTERISTICS	25
4.3.1. Installation	25
4.3.2. Dimensions	25
4.3.3. Weights	25
4.4. POWER SUPPLY AND CONSUMPTION	26
4.5. SYSTEM RELIABILITY	26
4.5.1. Mean Time Between Failures (MTBF)	26
5. RADIO CHARACTERISTICS	27
5.1. TRANSMITTER CHARACTERISTICS	27
5.1.1. Nominal Output Power	27
5.1.2. Automatic/Manual Power Control (ATPC/MTPC)	27
5.1.3. TX oscillator frequency tolerance	28
5.2. RECEIVER CHARACTERISTICS	28
5.2.1. Receiver Threshold 4xE1 - 7 MHz BW	28
5.2.2. Receiver Threshold 8xE1 - 7 MHz BW	28
5.2.3. Receiver Threshold 8xE1 - 14 MHz BW	28
5.2.4. Receiver Threshold 16xE1 - 14 MHz BW	29
5.2.5. Receiver Threshold 16xE1 - 28 MHz BW	29
5.2.6. Receiver Threshold 20xE1 - 14 MHz BW	29
5.2.7. Receiver Threshold 40xE1 - 28 MHz BW	29
5.2.8. Receiver Threshold 50xE1 - 28 MHz BW	30

5.2.9.	Receiver Threshold 75xE1 - 28 MHz BW	30
5.2.10.	Maximum input level.....	30
5.2.11.	RX oscillator frequency tolerance	30
5.2.12.	Noise Figure	30
5.3.	INTERFERENCE SENSITIVITY	31
5.3.1.	Co-channel interference sensitivity	31
5.3.2.	Adjacent channel interference sensitivity	31
5.4.	SYSTEM PERFORMANCE.....	32
5.4.1.	System Gain.....	32
5.4.2.	Equipment background BER (Residual BER).....	32
5.4.3.	System Signature	32
5.5.	DIPLEXER AND ANTENNA INTERFACE.....	33
5.5.1.	General description.....	33
5.5.2.	RF-Coupler	33
5.5.3.	Interface to Antenna feeder system – non integrated antennas.....	33
5.6.	IFU-ODU INTERFACE	34
5.6.1.	Cable interface characteristics	34
5.6.2.	Cable characteristics	34
5.7.	RADIO PROTECTION SWITCHING (RPS)	35
5.7.1.	Specification of the protection switching system	35
5.7.2.	Switching criteria and switching operation time, Rx.....	35
5.7.3.	Switching criteria and switching operation time, Tx.....	35
6.	BASEBAND CHARACTERISTICS.....	36
6.1.	USER INTERFACES	36
6.2.	ETHERNET FUNCTIONALITY	36
6.2.1.	General	36
6.2.2.	Ethernet Traffic Mapping	36
6.2.3.	Flow Control.....	36
6.2.4.	MAC learning	36
6.2.5.	Link-Loss Failure pass through on the Ethernet port.....	36
6.3.	TRANSMISSION INTERFACES	37
6.3.1.	Interface characteristics 1.5 Mbit/s.....	37
6.3.2.	Interface characteristics 2 Mbit/s.....	37
6.3.3.	Interface characteristics 155 Mbit/s electrical	37
6.3.4.	Interface characteristics 155 Mbit/s optical - Intermediate Reach.....	37
6.3.5.	Interface characteristics 155 Mbit/s optical - Long Reach 1300nm.....	38
6.3.6.	Interface characteristics 155 Mbit/s optical - Long Reach 1500nm.....	38
6.3.7.	Interface characteristics Ethernet – 10/100 BASE-TX:.....	38
6.4.	AUXILIARY INTERFACES.....	39
6.4.1.	64 kb/s channel characteristics	39
6.4.2.	Service telephone/Orderwire interfaces.....	39
6.4.3.	Alarm and Control Unit.....	40
7.	MANAGEMENT SYSTEM CHARACTERISTICS	41
7.1.	GENERAL	41
7.1.1.	Event logging.....	41
7.1.2.	Monitoring of system performance.....	41
7.1.3.	Security management.....	42
7.2.	ECC (EMBEDDED COMMUNICATION CHANNEL).....	43
7.2.1.	IP Routing.....	43
7.2.2.	Embedded SNMP agent.....	43
7.3.	INTERFACES TO THE SUPERVISION SYSTEM	43
7.3.1.	General	43
7.3.2.	LEDs.....	43
8.	REFERENCES	44
9.	TERMINOLOGY.....	46

APPENDIX 1 – ODU/Diplexer sub-band range48

List of Figures	Page
Figure 2-1 IFU, 1+0 system.....	13
Figure 2-2: PDH X-Connect.....	14
Figure 2-3 ODU, 1+0 System.....	16
Figure 3-1 System Block Diagram 1+0 Terminal	18
Figure 3-2 System Block Diagram 1+1 HSB/FD Terminal	19
Figure 3-3 System Block Diagram Space Diversity Terminal	19
Figure 3-4 System Block Diagram XPAND Traffic Node.....	20
Figure 4-1 Principle block diagram for a radio system	24

List of Tables	Page
Table 4-1 Frequency bands ETSI.....	22
Table 4-2 Frequency bands ANSI.....	23
Table 4-3 ETSI Equipment Class	24
Table 4-4 Power consumption terminal.....	26
Table 4-5 Maximum power consumption units.....	26
Table 5-1 Nominal output power.....	27
Table 5-2 Receiver threshold 4xE1 in 7 MHz channel.....	28
Table 5-3 Receiver threshold 8xE1 in 7 MHz channel.....	28
Table 5-4 Receiver threshold 8xE1 in 14 MHz channel.....	28
Table 5-5 Receiver threshold 16xE1 in 14 MHz channel.....	29
Table 5-6 Receiver threshold 16xE1 in 28 MHz channel.....	29
Table 5-7 Receiver threshold 20xE1 in 14 MHz channel.....	29
Table 5-8 Receiver threshold 40xE1 in 28 MHz channel.....	29
Table 5-9 Receiver threshold 50xE1 in 28 MHz channel.....	30
Table 5-10 Receiver threshold 75xE1 in 28 MHz channel.....	30
Table 5-11 Maximum input signal level.....	30
Table 5-12 Co-Channel Interference Sensitivity	31
Table 5-13 Adjacent Channel Interference Sensitivity	31
Table 5-14 System gain	32
Table 5-15 Typical signature values.....	32
Table 5-16 RF-Coupler loss	33
Table 5-17 ODU flanges and waveguide.....	33
Table 5-18 Cable lengths, IFU-ODU cable	34
Table 7-1 LED status indications	43

This page is intentionally left blank

1. INTRODUCTION

The first chapter in this document contains information about the **Evolution Series** in general. Chapter two and onwards cover the **Evolution Series - XPAND** specifically.

The Nera Evolution Series microwave radio dramatically changes the operations for wireless transmission network owners. With a common platform architecture, which is fully software configurable; transmission capacity, system configurations and transmission protocols can be changed to adapt to future needs. Evolution Series dramatically reduces the cost of ownership. With significantly reduced number of parts and high MTBF Evolution Series ensures maximum uptime and low maintenance.

The Evolution Series microwave radio is designed to transmit data rates from about 6 Mb/s to 600Mb/s, in the frequency bands from 5 GHz to 38 GHz. The configuration of capacity and modulation is software configurable, giving an optimal balance between system gain and spectral efficiency.

Network operators can easily future proof the network as the microwave radio can easily adapt to the evolution of the transmission network. Growing traffic and the convergence of network technologies causes changing requirements, such as capacity upgrades, change of transmission systems between PDH, SDH/SONET and pure Ethernet; all this is simply implemented by software configuration change and change of interface modules. The available interfaces range from E1, T1, E3, DS3 STM-1/OC-3, STM-4/OC12 to 10/100BASE-TX and Gigabit Ethernet.

The Evolution Series product can be configured to work in three different modes. Payload capacity is also configurable and is selected by SW licences. Changes and upgrades can be done by the user without HW changes to the basic platform.

XPAND features (ETSI)

- Scalable 8, 16, 32, 40, 80, 100, 160 Mb/s transmission capacity
- 7, 14 and 28 MHz BW
- Mix of Ethernet and E1s
- 4, 8, 16, 20, 40, 50, 75 x E1 capacity
- Ethernet 1xFE, scalable with 2 Mbit/s granularity up to 100Mb/s
- Embedded PDH cross-connect (Ethernet and E1)
- Ring protection for E1s (also E1's carrying Ethernet traffic), based on SNCP
- STM-1 interface for direct connection to a SDH based network

The **XPAND** variant (ANSI)

- Scalable 6, 12, 24, 48, 100 Mb/s transmission capacity
- 5, 10, 20 and 30 MHz BW
- Mix of Ethernet and T1s
- 4, 8, 16, 32, 64 x T1 capacity
- Ethernet 1xFE, scalable with 1.5 Mbit/s granularity up to 100Mb/s
- Embedded PDH cross-connect (Ethernet and T1)
- Ring protection for T1s (also T1's carrying Ethernet traffic), based on SNCP
- OC-3/STS-3 interface for direct connection to a SONET based network

The **IP** variant (ETSI and ANSI)

- 1xFE, 4xFE or 1xGbE
- Scalable 100, 150, 300 & 600 Mb/s transmission capacity
- 28, 40, 50 and 56 MHz BW
- CCDP configuration with XPIC

The **METRO** variant (**ETSI** and **ANSI**)

- 155 Mb/s, 311Mb/s and 622 Mb/s transmission capacity
- Configurations up to 3+1/4+0
- CCDP configuration with XPIC
- 28, 40, 50 and 56 MHz BW
- Options for embedded ADM mux / X-connect
- TDM traffic : 63xE1, 3xE3/DS3, 64xT1
- Advanced Ethernet : 4xFE and 1xGbE with QoS, nxVC12(VT1.5), VC-3(STS-1) or VC-4(STS-3-3c) mapping
- Traffic Node with 4 radio directions, SNCP with Ring, Chain, Star or Mesh topology

The Evolution Series is an integrated part of Nera's wide product portfolio, from the leading microwave specialist. The product portfolio covers products for all type of professional wireless carrier systems. Nera's microwave experience dates back more than 50 years, with a leading position in this field. The Evolution Series radio is integrated in Nera's new EM/NMS system, NetMaster.

1.1. Features

The Evolution Series microwave radio utilises the state-of-the-art technology to achieve low power consumption and high reliability.

A high degree of RF circuit integration is achieved using Microwave Monolithic Integrated Circuits (MMIC's). This, combined with a direct at RF modulation architecture, enables a broadband and compact ODU design. Furthermore, patented power amplifier technology delivers low power consumption which further enhances reliability.

The modem contains multidimensional coded modulation, combined with a powerful block code. The resulting two-stage error correction improves system margin over traditional single FEC systems such as QAM, TCM or MLCM. The modem is extremely flexible, enabling an optimum configuration for all capacities and channel plans.

The ODU Unit consists of a XVCR and a Diplexer Unit. The ODU is frequency and capacity agile. The tuning range is very wide and most frequency bands can be covered by four variants for the whole band. The frequency setting is easy and is performed locally or remotely by the LCT function.

The ODU can for most frequency bands be mounted directly on the antenna, both in unprotected and protected configurations. The ODU can also be mounted on the antenna pole, using a short flexible waveguide to the antenna.

The InterFace Unit (IFU) is an extremely modular system, catering for the various system configurations and traffic interfaces by plug-in modules. The IFU can easily be expanded from a single channel system up to a traffic node handling up to 8 ODUs. The IFU contains the user interfaces, baseband processing and multiplexing, management and radio interface.

The demodulator contains an integrated digital interference canceller, which can be used to provide the XPIC function, enabling two carriers to be transmitted over the same frequency, using dual polarised antennas.

The embedded PDH cross-connect allows flexible routing of Ethernet traffic and E1/T1-traffic between the radio interfaces and the user interfaces.

The optional DXC-Unit in combination with an STM-1/OC-3 interface provides a direct interface from this platform to a SDH/SONET network.

The equipment configuration, licenses and the operating software can be stored on the memory key available for plug-in at the front of the equipment or downloaded to a computer. When a new Supervisory Unit is inserted, the equipment configuration can then easily be restored to the radio equipment.

1.2. Network Applications

The Evolution Series microwave radio is ideally suited for a wide range of applications. Due to the flexibility in configurations, the choice of traffic interfaces and the capacity scalability, it can easily adapt to the specific requirements of a given network application. The flexibility and ease- of upgrade, future proof the investment, as the equipment can grow with the increasing traffic demand as well as easily adapt to other transmission technologies.

Mobile (BTS) Backhaul

- The Evolution Series microwave radio is ideal for demanding and critical application such as backhaul of BTS traffic. Where loss of traffic directly results in loss of revenue, reliability and maximum uptime are critical parameters for the network operator. The Evolution Series reliable and flexible architecture as well as high system gain, ensures increased availability of the offered services, and a secured revenue stream. The embedded PDH (E1/T1) cross-connect enables routing of traffic without the need for external cabling. Further, the E1/T1 traffic circuits can be individually protected via ring or mesh topologies, and various traffic types can be mixed, sharing the transmission capacity of the radio. The radio can be configured for a wide range of capacities, ensuring an optimal utilization of the available spectrum as well as capabilities for upgrading when traffic demand increases or new services are introduced.
- With the introduction of new mobile technologies (3G), as an overlay network or a Greenfield installation, the aggregate capacity demand typically raise above 16xE/T1. A flexible platform that can grow with capacity requirements represent large savings in the network operation, compared to more traditional network designs.

Evolution XPAND radio chain with embedded E1/T1 cross-connect

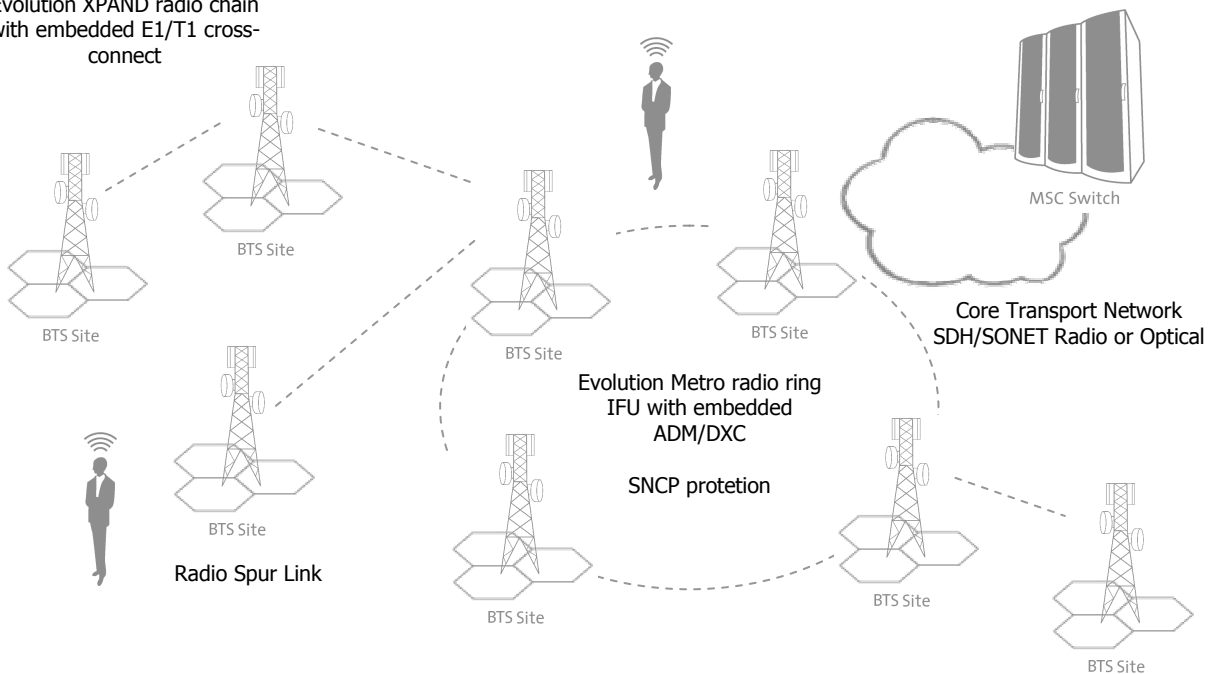

LMDS/FWA Backhaul

- *LMDS/FWA backhaul.* The Evolution Series radio is well suited for backhaul of traffic from Point-to-MultiPoint radio access systems like WiMax. With a selectable capacity, ranging from about 6Mb/s to 600Mb/s, the Evolution Series radio can easily be deployed in small network as well as in larger constellations and networks with several sites linked together. The choice of pure TDM (E1/T1), Ethernet/Gigabit Ethernet, or 155Mb/s SDH/SONET, or a combination of TDM (E1/T1) with Ethernet/Gigabit Ethernet, makes the Evolution Series suitable for any FWA network installation.
- *DSLAM backhaul.* The instruction of xDSL services can in some cases uncover a new challenge. The local transmission network may only be dimensioned for the POTS traffic and is not suited for high speed data. Upgrading the local network to fiber might not be feasible due to time and/or cost of such upgrade. The Evolution Series microwave radio offers an easy and flexible solution to this challenge. The Evolution Series microwave radio can offer backhaul of the DSLAM to the optical backbone network, whether the network interfaces are PDH, ATM/SDH/SONET or Ethernet/Gigabit Ethernet. With the Evolution Series radio, the various traffic types are catered for merely by change of interface modules.

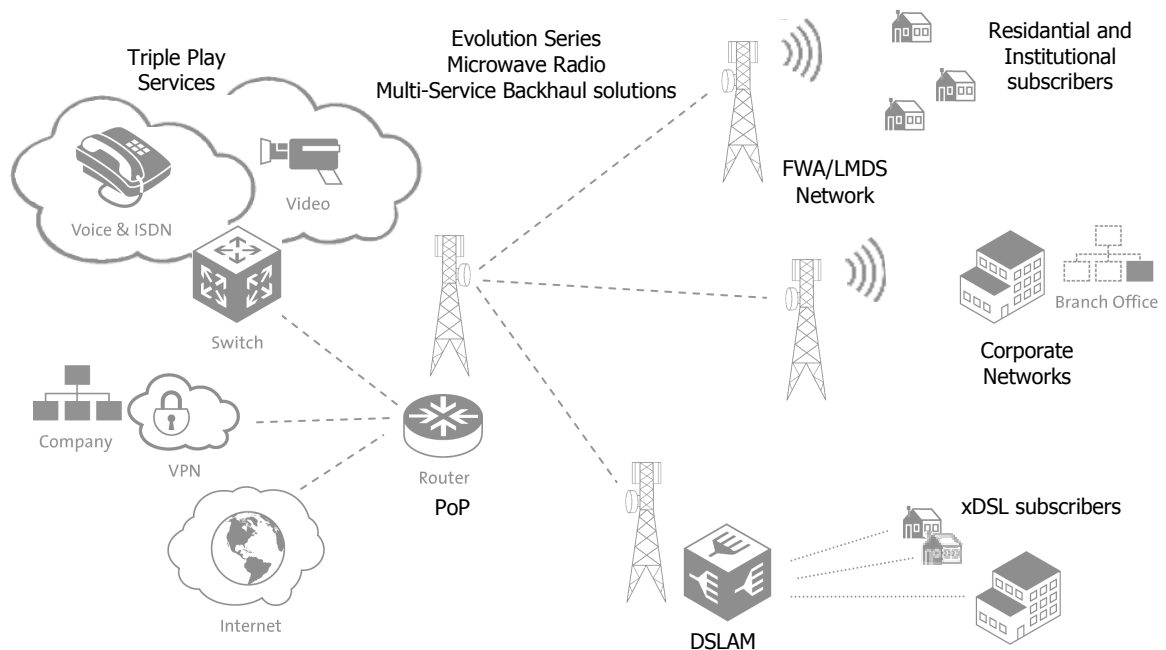

Private Networks Operators

- *Corporate/Campus Networks.* The Evolution Series radio is a good alternative to more common unlicensed microwave solutions. With choice of pure TDM (E1/T1/E3/DS3), Ethernet/Gigabit Ethernet, 155Mb/s SDH/SONET, or a combinations of TDM (E1/T1/E3/DS3) with Ethernet/Gigabit Ethernet, makes the Evolution Series suitable for most private networks, whether they are carrying legacy services or data only. Flexibility and simplicity, combined with a predictable reliability, proves for many network owners to be an unbeatable combination.

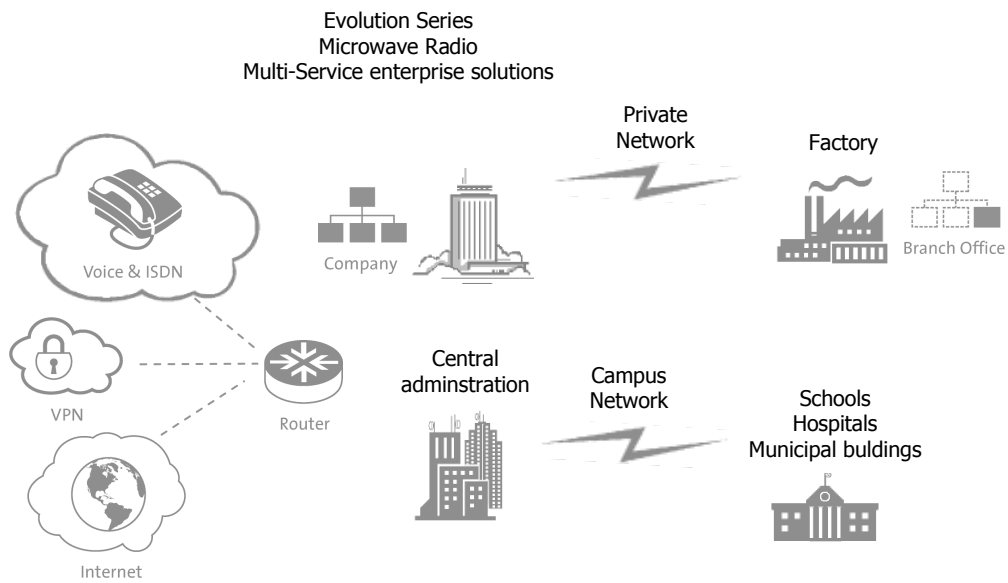

2. SYSTEM DESCRIPTION

The Evolution Series microwave radio system comprises an indoor part (IFU), and an outdoor part (ODU) and an antenna. The IFU and ODU is interconnected with coaxial cable which carries transmit and receive user traffic, management communication between the IFU and ODU, and the power supply to the ODU.

2.1. IFU with PDH X-Connect

The Evolution Series IFU is a 1RU basic frame, containing 9 plug-in slots for various modules. The modular architecture with plug-in slots enables a high degree of flexibility, ease of upgrading/changing configurations and easy maintenance.

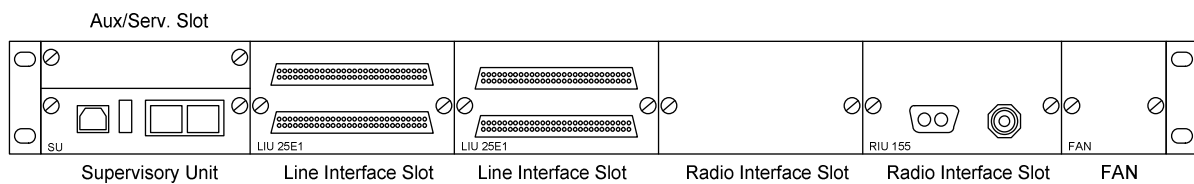

Figure 2-1 IFU, 1+0 system

The basic IFU frame is common in all configurations and up to four basic IFU basic frames can be stacked together through a rear connection. Cages with connection panel housing 2 or 4 IFUs are available.

Embedded 4-port X-connect for routing of E1/T1 and Ethernet traffic:

The basic IFU frame contains an embedded 4-port PDH X-Connect (PXC). Each of these 4 ports (0, 1, 2 and 3) can be assigned to the Ethernet Interface (on Supervisory Unit), E1/T1-Line Interface Unit, Radio Interface Unit, or IFU-rear-interface (IFU expansion). Ethernet traffic is carried as E1/T1-frames through the X-connect. The capacity through the 4 PXC-ports is limited by the unit each port is connected to as shown in the table below:

PXC connected to:	Maximum Capacity:
Ethernet port (on SU Unit)	50E1 or 64T1 (100Mb/s)
E1 Line Interface	25E1
T1 Line Interface	16T1
Radio Interface	75E1 or 96T1
IFU rear Interface (IFU expansion)	63E1 or 84T1

Each of the E1/T1 carried through the 4 PXC-ports can be X-connected (any to any, non-blocking). Each E1/T1-output from the PXC can be configured to be sourced from any E1/T1-input. All E1/T1-outputs may have the same source (one-to-many principle). Two of the PXC-ports (port 2 and 3) can be configured to go to Radio Interfaces. SNCP is available for each E1/T1. When configuring the PXC, each individual E1/T1 may be set up with SNCP activated or not activated.

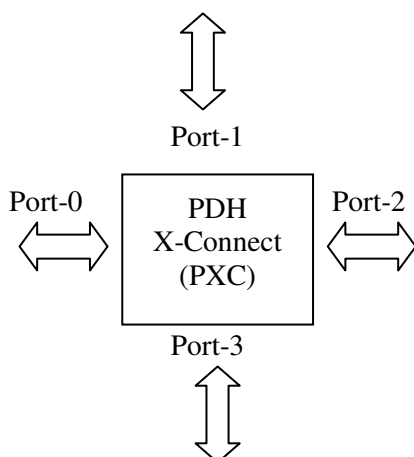

Figure 2-2: PDH X-Connect

Configuration examples:

Terminal Configuration:	Units and location in IFU:	PXC-port to be used:	Comment:
100Mbps FE + 25E1, 1+0 (one IFU)	1 x RIU in IFU slot 5 1 x 25E1 Line interface in IFU slot 3 SU-FE in IFU slot 1	3 1 0	PXC-port 2 not used
100Mbps FE +1-25E1, HSB (one IFU)	1 x RIU in IFU slot 5 1 x RIU in IFU slot 4 SU-FE in IFU slot 1 1 x 25E1 Line Interface in IFU slot 3	3 3 0 1	PXC-port 2 not used. In HSB is traffic switched after the PXC
50Mbps FE +26-50E1, HSB (one IFUs)	1 x RIU in IFU slot 5 1 x RIU in IFU slot 4 SU-FE in IFU slot 1 25E1 Line Interface in IFU slot 3 25E1 Line Interface in IFU slot 2	3 3 0 1 2	All PXC-ports used.
100Mbps FE + 16T1, 1+0 (one IFU)	1 x RIU in IFU slot 5 1 x 16T1 Line interface in IFU slot 3 SU-FE in IFU slot 1	3 1 0	PXC-port 2 not used
100Mbps FE +1-16T1, HSB (one IFU)	1 x RIU in IFU slot 5 1 x RIU in IFU slot 4 SU-FE in IFU slot 1 1 x 16T1 Line Interface in IFU slot 3	3 3 0 1	PXC-port 2 not used. In HSB is traffic switched after the PXC
50Mbps FE +17-32T1, HSB (one IFUs)	1 x RIU in IFU slot 5 1 x RIU in IFU slot 4 SU-FE in IFU slot 1 16T1 Line Interface in IFU slot 3 16T1 Line Interface in IFU slot 2	3 3 0 1 2	All PXC-ports used.

Plug-in units:

- The lower left position contains the Supervisory Unit. The Supervisory Unit is handling the configuration of all system units as well as reporting system status to the EM/NMS system. One of the LAN-ports on the Supervisory Unit may be used for Ethernet User traffic.
- The rightmost position houses the FAN Unit, handling the ventilation and temperature management of the IFU frame. The FAN Unit is always included with the IFU basic frame. The LED on the FAN Unit is an alarm for the IFU basic frame.
- The Line Interface slots houses the various optional user traffic interfaces.
- The two Radio Interface slots houses Radio Interface Units (RIUs) or Power Supply Units. The RIU provides connection to the ODU and includes power supply to the unit and the ODU.
- The upper Aux/Serv. slots houses any Auxiliary or Service Channel units, such as Alarm and Control Unit, Wayside Unit, 64 kb Data Channels Unit and EOW Unit. Up to three slots are available, limited by double height Line Interface Units or DXC (used with STM-1/OC-3-interface).

All units can be replaced in the field. Non traffic carrying units can be replaced without interrupting the service. See paragraph 2.3 for further description of the various plug-in units.

2.2. OutDoor Unit (ODU) description

The ODU hardware is capacity and modulation independent. It consists of a XCVR and a Diplexer. The XCVR is tuneable over the whole frequency band, both high and low part. The diplexer determines the sub-band coverage. The ODU is normally mounted directly to the antenna for all configurations. In HSB and 1+1/2+0 configurations an RF-Coupler is used when connecting the ODU to the antenna interface.

An optional pole mount kit is available.



Figure 2-3 ODU, 1+0 System

2.3. IFU Unit Descriptions

2.3.1. Supervisory Unit

The Supervisory Unit is handling the configuration of all the system units as well as reporting system status to the EM/NMS system. It has two 10/100 BASE-TX Ethernet ports and two USB ports; one host port and one device port.

The Ethernet ports are connected to an internal switch and can both be used for connection to the EM/NMS system and/or for connecting terminals together in an Ethernet LAN.

One of the Ethernet ports (LAN2) can be used for user traffic. The Ethernet traffic is mapped in to nxE1 or nxT1 and then into the radio-frame mixed with TDM circuits. Capacity is limited by the configured link capacity. Ethernet capacity is selectable in E1/T1 steps.

The USB host port serve as the LCT port. The USB ports can also be used to connect IFUs together, and the host port can be used as interface for storage devices for SW backup and download.

2.3.2. Radio Interface Unit – RIU

The RIU contains the interface for connecting the IFU to one ODU with a single coaxial cable. It also contains the connector for power supply to IFU and ODU.

2.3.3. Line Interface Unit – LIU

The LIU contains the interface for connecting the user traffic to the IFU. In addition to the LAN-port on the Supervisory Unit, LIUs are available for E1 or T1. For interfacing to a SDH/SONET system, a STM-1/OC-3 LIUs is used in combination with the DXC-Unit.

2.3.4. SDH/SONET Digital X-Connect Unit

The optional SDH/SONET DXC is used in combination with the STM-1/OC-3 LIU to provide a SDH/SONET interface on Evolution XPAND. The multiplex structure is selectable between SDH and SONET. The DXC Unit handles the mapping and timing features necessary to interface to a SDH/SONET system. The SETS function handles node synchronisation and selection of synchronisation sources.

2.3.5. Alarm and Control Unit

The unit provides interfaces for collection of external alarms or analogue values, and relays for external alarm and control outputs.

- Eight alarm inputs
- Four relay outputs
- Seven analogue inputs

2.3.6. 64 kb/s Serial Channel Unit

The unit contains four 64kbit/s channel interfaces to be used for user traffic. Two with co-directional interface, one with contra-directional interface and one V.11 interface (without byte timing).

2.3.7. EOW Unit (Service channel)

The EOW Unit provides a party line service channel for voice communication to other terminals in the network. It provides the following functions:

- Selective call with two digit telephone number.
- Collective call by pressing *-button.
- Built-in bridge for east/west connections.
- 4-wire analogue interfaces for connection to other service channel equipment.
 - One 4-wire Interface with level adjustment
 - Two Other Equipment (OE1 and OE2) interfaces
 - The two OE interfaces can be configured for Daisy-chain operation
- The pinning configuration is adapted to standard Ethernet CAT-5 cable; this enables use of standard cables.

The IFU can be equipped with two service telephone plug-in units unit. A standard telephone handset connects to the unit.

2.3.8. Fan Unit

The Fan Unit handles temperature management of the IFU and consists of three fans. An alarm is generated if one of the fans should fail. The Fan Unit is field replaceable without interrupting the service.

2.3.9. Power Supply Unit

This unit is used if the IFU is not equipped with RIU (Radio Interface Unit) or for duplicated power supply in a 1+0 configuration.

3. SYSTEM CONFIGURATIONS

Evolution Series XPAND is available in the following configurations:

- 1+0 (Unprotected)
- 1+1 Hot Standby
- 1+1 Hot Standby – Dual antenna/Space Diversity
- 1+1 Frequency Diversity
- 1+1 Frequency Diversity – Space Diversity
- 1+1 Frequency Diversity – Dual Polarised
- 2+0 Dual frequency – Single Polarisation (DF-SP)
- 2+0 Dual frequency – Alternating Polarisation (AP)

3.1. 1+0 system

The 1+0 configuration consists of an IFU basic frame, an E1 or T1 Interface Unit, a Radio Interface Unit, a single coaxial cable to the ODU and an ODU mounted directly on the antenna or near the antenna. When the ODU is not mounted directly on the antenna, a short flexible waveguide is used to connect the ODU to the antenna port.

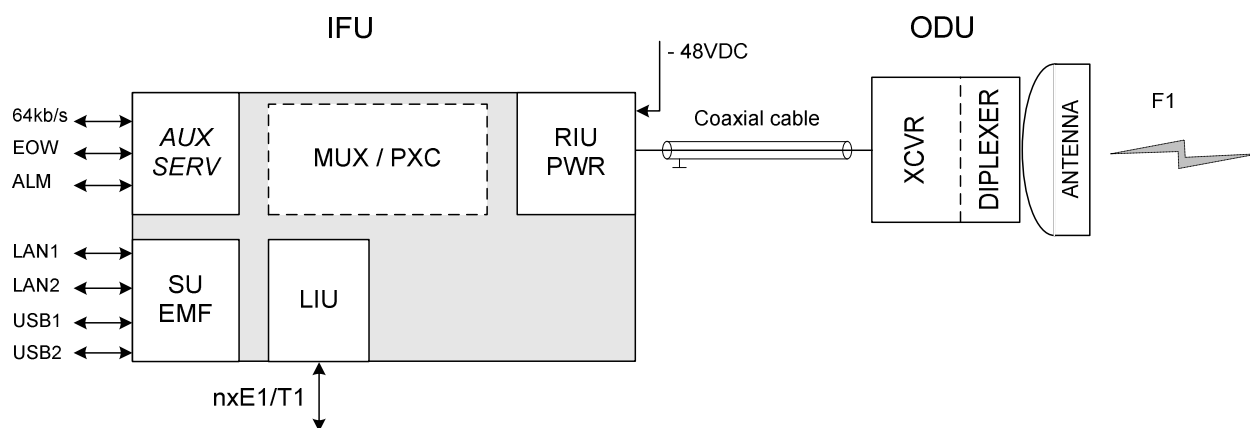

Figure 3-1 System Block Diagram 1+0 Terminal

Legend

ALM	External alarm input/output
AUX	Auxiliary functions
EMF	Embedded Management Functions
EOW	Engineering Order Wire
LAN	Local Area Network port (10/100BASE-TX Ethernet)
LIU	Line Interface Unit
RIU	Radio Interface Unit
PWR	Power Supply
PXC	PDH X-Connect
SERV	Service functions
SU	Supervisory Unit
USB	Universal Serial Bus
XCVR	Transmitter/Receiver

3.2. 1+1 HSB / 1+1 FD system

The 1+1 HSB or 1+1 Frequency Diversity configuration, consist of an IFU basic frame, an E1 or T1 Interface Unit, two Radio Interface Units, two coaxial cables to the ODUs and two ODUs mounted on an RF-Coupler Unit. The RF-Coupler can be asymmetrical or symmetrical, and the RF-Coupler/ODU assembly can be mounted directly on the antenna or near the antenna. When the RF-Coupler is not directly mounted, a short flexible waveguide is used to connect the RF-Coupler to the antenna port.

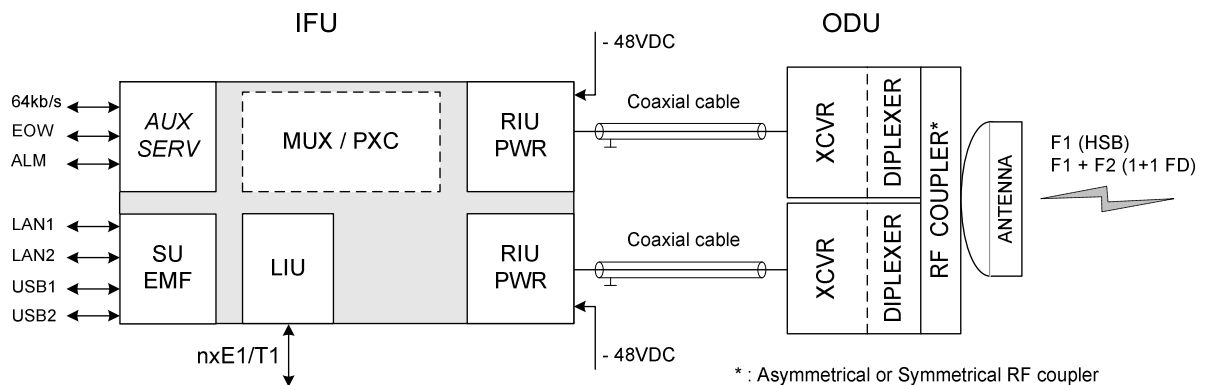

Figure 3-2 System Block Diagram 1+1 HSB/FD Terminal

3.3. Space Diversity/Dual Antenna system

The 1+1 HSB or 1+1 Frequency Diversity configuration can be configured for Space Diversity or Dual Antenna. This configuration uses two antennas, and the two ODUs are mounted one on each antenna without using an RF-Coupler. The use of Space Diversity/Dual Antenna reduces the RF loss and provides path diversity, which can improve system performance (subject to frequency band and path type and length).

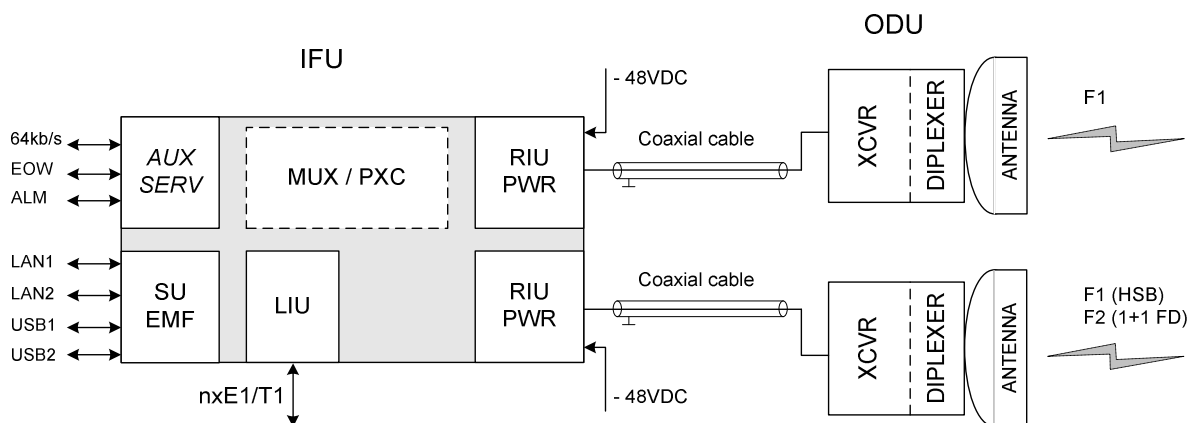

Figure 3-3 System Block Diagram Space Diversity Terminal

3.4. Node configuration

Evolution series XPAND can be configured as a traffic node with up to eight unprotected or four protected antenna directions. The node performs digital x-connect of traffic at E1/T1 level between the directions.

This node can be connected to a SDH/SONET system by using the STM-1/OC-3 LIU in combination with a DXC plug in unit.

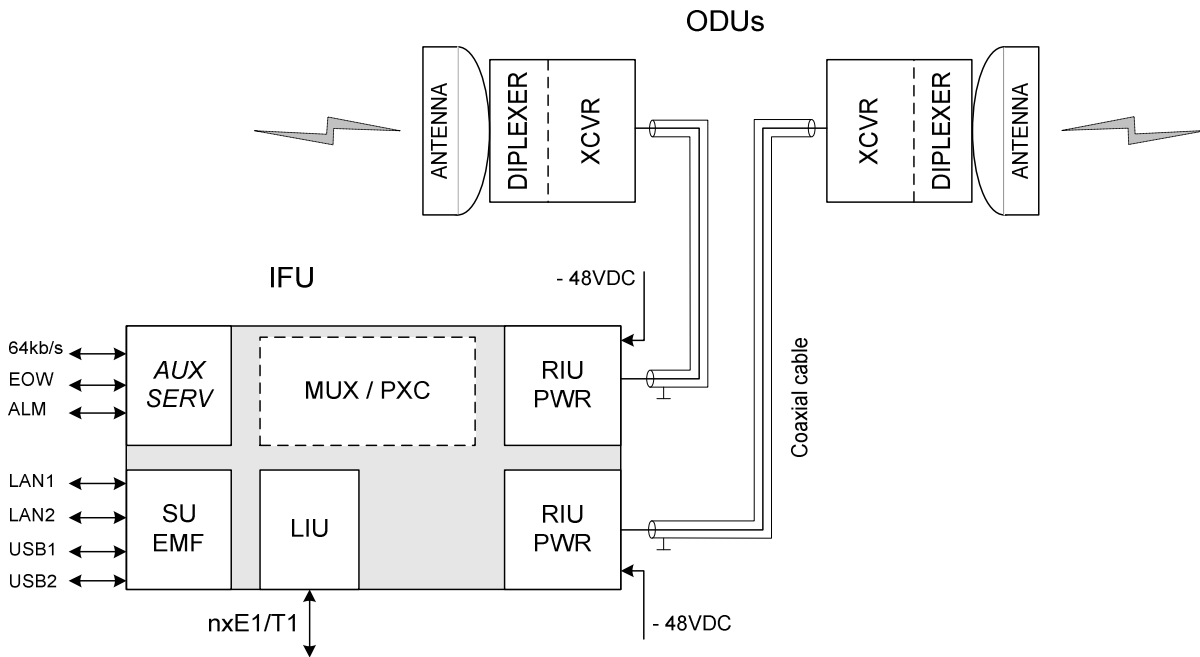

Figure 3-4 System Block Diagram XPAND Traffic Node

4. EQUIPMENT CHARACTERISTICS

The table below shows capacities vs. channel bandwidth and modulation type. Capacity is shown in terms of E1s/T1s, but may be mixed with Ethernet traffic to a combined capacity as shown in the table.

Transmission capacity	Bandwidth and Modulation				
	4 State	16 State	32 State	64 State	128 State
4 x E1	7 MHz				
8 x E1	14 MHz	7 MHz			
16 x E1	28 MHz	14 MHz			
20 x E1		14 MHz			
40 x E1*		28 MHz			
50 x E1*			28 MHz		
75 x E1*			55/56 MHz	40 MHz	28 MHz
4 x T1	5 MHz				
8 x T1	10 MHz	5 MHz			
16 x T1	20/25 MHz	10 MHz			
32 x T1*		20/25 MHz			10 MHz
64 x T1*		40/50/55 MHz	30 MHz		20/25 MHz

* Capacities from 40xE1 or 32xT1 and up require SW-license.

4.1. Frequency bands

The **Evolution Series XPAND** is available in ITU-R, CEPT, FCC and national frequency bands according to the following tables. The BW given in the last column is for information only and indicates which BWs the plan includes. Details about ODU tuning range is found in Appendix 1.

Frequency Band	Frequency [GHz]	Channel Plan	Duplex spacing [MHz]	BW [MHz]
L6 GHz	5.9-6.4	ITU-R F. 383-7 CEPT 14-01E	252.04	29.65
U6 GHz	6.4-7.1	ITU-R F.384-8 CEPT 14-02 E	340	20/30/40
7 GHz	7.1-7.4	ITU-R F.385-7 Annex 3	196	28
7 GHz	7.1-7.4	CEPT 02-06 Annex 1	154	7/14/28
7 GHz	7.1-7.4	ITU-R F.385-8 Rec. 1-4	161	7/14/28
7 GHz	7.1-7.4	ACA Rali FX3	270	30
7 GHz	7.2-7.5	ITU-R F.385-8 Rec. 1-4	161	7/14/28
7 GHz	7.4-7.7	ITU-R F.385-8 Annex 3	168	28
7 GHz	7.4-7.7	ITU-R F.385-8 Annex 1,4	154	28
7 GHz	7.4-7.7	ITU-R F.385-8 Annex 1, 1 CEPT 02-06 Annex 1	154	7/14/28
7 GHz	7.4-7.7	ITU-R F.385-8 Rec 1-4	161	7/14/28
7 GHz	7.4-7.9	ITU-R F.385-8 Annex 4	245	7/14/28
7 GHz	7.1-7.7	"Korea"	300	30

Frequency Band	Frequency [GHz]	Channel Plan	Duplex spacing [MHz]	BW [MHz]
8 GHz	7.7-8.3	ITU-R F.386-6 Annex 1	311.32	29.65
8 GHz	7.7-8.3	7.7-8.3 GHz, 40 MHz CS	310	40
8 GHz	7.9-8.4	ITU-R F.386-6 Annex 4	266	7/14/28
8 GHz	7.9-8.5	CEPT 02-06	310	7/14/28
8 GHz	8.2-8.5	ITU-R F.386-6 Annex 3	119 126	14 7
8 GHz	8.2-8.5	ITU-R F.386-6 Rec. 1	151.614	7
11 GHz	10.7-11.7	ITU-R F. 387-9 Rec. 1	530	40/30
11 GHz	10.7-11.7	ITU-R F. 387-9 Annex 1 CEPT 12-06 Rec. 1	530	40
11 GHz	10.7-11.7	ITU-R F. 387-9 Annex 2 CEPT 12-06 Rec. 3	490	40
13 GHz	12.7-13.3	ITU-R F. 497-6 CEPT 12 02F	266	7/14/28
15 GHz	14.4-15.35	ITU-R F.636-3	490	7/14/28
15 GHz	14.5-15.35	ITU-R F.636-3	420	7/14/28
15 GHz	14.6-15.2	CFT Mexico	315	14/28
15 GHz	14.5-15.35	CEPT 12-07E	728	7/14/28
15 GHz	14.5-15.35	ACA RALI FX3	644	14/28
18 GHz	17.7-19.7	ITU-R F.595-8 CEPT 12-03E	1010	7/13.75/27.5/55
18 GHz	17.7-19.7	ITU-R F.595-8 Norma No 15/96	1560	13.75/27.5/55
18 GHz	17.7-19.7	China	1092.5	27.5
18 GHz	17.7-19.7	China	1120	55
23 GHz	21.2-23.6	ITU-R F.637-3 Annex 3 CEPT 13-02E	1008	7/14/28/56
23 GHz	22.0-23.6	RA 352	1008	56
23 GHz	21.2-23.6	ITU-R F.637-3 Annex 4	1200	50
23 GHz	21.2-23.6	ITU-R F.637-3 Annex 1	1232	7/14/28/56
26 GHz	24.25-26.5	ITU-R F.748-4 Annex 1 CEPT 13-02E	1008	7/14/28/56
32 GHz	31.8-33.4	ITU-R F.1520-2 CEPT (01)02	812	7/14/28/56
38 GHz	37.0-39.5	ITU-R F.749-2 Annex 1 CEPT 12-01E	1260	7/14/28/56
38 GHz	38.6-40.0	ITU-R F.749-2 Annex 3, 1	700	25/50

Table 4-1 Frequency bands ETSI

Freq. Band	Frequency [GHz]	Channel Plan	Duplex spacing [MHz]	BW [MHz]
L6 GHz	5.9 - 6.4	CFR47 101.147 Table i SRSP –305.9	252.04 252.04	4.94/9.88/29.65 29.65
U6 GHz	6.4 - 7.1	SRSP –306.4 CFR47 101.147 Table l	100/340 160/170	10/30 5/10
7 GHz	7.1 - 7.4	SRSP –307.1	175	5/10/30
7 GHz	7.4 - 7.7	SRSP –307.1	150	5/10/20/30
8 GHz	7.7 - 8.3	SRSP –307.7	300	10/20/30
11 GHz	10.7 - 11.7	CFR47 101.147 Table o SRSP –310.7	490	5/10/30/40
18 GHz	18.7-19.7	CFR47 101.147 Table r	1560	10/20/40
23 GHz	21.2-23.6	CFR47 101.147 Table s	1200	5/10/20/30/40/50
38 GHz	38.6-40.0	CFR47 101.147 Table v	700	7.25/12.5/25/50

Table 4-2 Frequency bands ANSI

4.2. General Equipment Specifications

4.2.1. Equipment Reference Points

A principle block diagram for a digital radio relay system, including the main blocks, is shown in Figure 4-1. The block diagram includes marked interface points, which serve as reference points for several technical parameters used in this document.

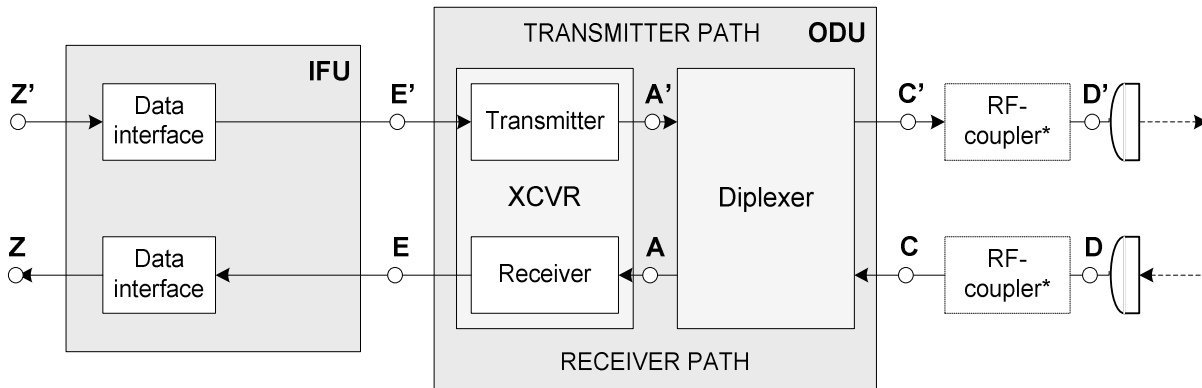

* The RF-Coupler is used in HSB and 1+1/2+0 single polarised configurations

Figure 4-1 Principle block diagram for a radio system

4.2.2. ETSI Equipment Class

The equipment is compliant to the relevant specifications in EN 302 217 for the following classes.

BW	Modulation	Class
7 MHz	QPSK	2
14 MHz	16 state	2 and 4
28 MHz	32 state / 128 state	4, 5A and 5B

Table 4-3 ETSI Equipment Class

4.2.3. Electromagnetic Compatibility Conditions (EMC)

ETSI: The equipment conforms to the EMC standard as specified in EN 301 489 part 1 and 4.

FCC: The equipment conforms to FCC Part 15 subpart B class A.

4.2.4. Safety conditions

The equipment conforms to EN 60215, EN 60950 and UL/CSA 60950. The optical interfaces conform to EN 60825-1 and EN 60825-2.

4.2.5. RoHS and WEEE compliance

The equipment is compliant to EU Directive 2002/95/EC (RoHS) and EU Directive 2002/96/EC (WEEE)

4.2.6. Equipment Type Approval

The equipment is type approved and labelled according to EU Directive 1999/5/EC.

The CE marking is located on both IFU and ODU.

4.2.7. Environmental conditions

The equipment conforms to the environmental classes defined in ETS-300-019:

- **Transportation:** ETSI-EN-300-019-1-2, class 2.3, public transportation.
(temperature range: -40 °C to +70 °C).
- **Storage:** ETSI-EN-300-019-1-1, class 1.2, weather protected,
not temperature-controlled storage locations.
(temperature range: -40 °C to +70 °C).
- **Use:** Indoor mounted units: Temperature range: -5 °C to +50 °C.
According to ETSI-EN-300-019-1-3, class 3.2, partly temperature-
controlled locations.
For temperatures between +45°C and +50°C the relative humidity
must be between 5% and 40%.

Outdoor mounted units: Standard temperature range: -33 °C to +50 °C.
According to ETSI-EN-300-019-1-4, class 4.1 , non weather
protected locations

*For temperatures below 0°C the equipment must be switched on
for at least 10 minutes in order to operate according to the
specifications.*

4.3. Mechanical Characteristics

4.3.1. Installation

The equipment is very easy and quick to install. It is designed for stationary use in split mount installations. IFU and ODU are interconnected with coaxial cable. One cable for each ODU is used. (i.e. Two cables needed for HSB, 1+1 FD and 2+0 systems). The IFU can be installed as a stand-alone unit, or it can be mounted in a standard 19" rack (Ref. IEC 297-2 and IEC 297-3), or in an ETSI standard cabinet (Ref. ETSI EN 300 119). The ODU¹ may be mounted directly to the antenna for antenna sizes up to and including 1.8 m. Alternatively the ODU can be supplied with a mount for a vertical column (Ø=60-115mm).

4.3.2. Dimensions

IFU ²	1+0/1+1/HSB:	444 mm (W) x 225 mm (D) x 44 mm (H), 17.5" x 8.9" x 1.73"
ODU	1+0, 6 - 11 GHz:	227 mm (W) x 140 mm (D) x 240 mm (H), 8.9" x 5.5" x 9.4"
ODU	1+0, 13 - 38 GHz:	206 mm (W) x 132 mm (D) x 210 mm (H), 8.1" x 5.2" x 8.4"
RF Coupler	6 - 11 GHz ³ :	232 mm (W) x 102 mm (D) x 415 mm (H), 9.1" x 4.0" x 16.3"
	13 - 38 GHz:	220 mm (W) x 106 mm (D) x 374 mm (H), 8.7" x 4.2" x 14.7"

4.3.3. Weights

IFU:	2.5 kg / 5.5 lbs
ODU 6 - 11 GHz:	8.0 kg / 17.7 lbs
ODU 13 - 38 GHz:	6.5 kg / 14.3 lbs
RF Coupler:	5 kg / 11 lbs

¹ The ODUs in 6 GHz are pole mounted

² The width and depth of the unit are exclusive flanges (mounting brackets) and table studs for free-standing mounting. Special brackets for mounting into different cabinets are available

³ The 6 GHz RF-coupler has a shorter antenna insert

4.4. Power supply and consumption

The equipment operates from a battery supply between -40.5 volt and -57 volt, nominally -48 volt DC according to EN 300 132-2. The primary DC-power is supplied to the indoor unit through a filtering function that includes input filter to attenuate the common mode noise.

The power to the outdoor unit is supplied from the indoor unit via the IFU-ODU coaxial cable.

Terminal without interface	L6-11 GHz		13-38 GHz	
	Average	Maximum	Average	Maximum
1+0 Terminal	65 W	71 W	52 W	58 W
HSB/1+1/2+0 Terminal	117 W	128 W	91 W	102 W

Table 4-4 Power consumption terminal

Unit	
ODU L6-11 GHz	48 W
ODU 13-38 GHz	35 W
Basic IFU, incl. SU and fans	13.5 W
Radio Interface Unit	9.3 W
3xE3/DS3 Interface Unit	3 W
25xE1 and 16xT1 Interface Unit	4 W
Auxiliary Units, 64 kb, Wayside and Alarm Unit	2 W
Service channel Unit	2.5 W
Line Interface Unit, Electrical or S-1.1 optical	2.3 W
Line Interface unit, L-1.1 or L-1.2 optical	4 W
DXC Unit	5.5 W

Table 4-5 Maximum power consumption units

4.5. System Reliability

4.5.1. Mean Time Between Failures (MTBF)

The MTBF figures are predicted and calculated according to methods in MIL-HDBK-217E including adjustment for experienced field data. MTBF for 1+0 Terminal with Line Interface Unit is about 30 years.

Unit name:	MTBF, 25 °C ambient temp: [Hours]
Transceiver Unit (ODU)	400 000
Basic IFU incl. one RIU	1 000 000
RIU	3 200 000
Supervisory Unit	3 200 000
Interface units	5 000 000-1 600 000
DXC	2 600 000

5. RADIO CHARACTERISTICS

5.1. Transmitter Characteristics

5.1.1. Nominal Output Power

The tolerance is ± 1.5 dB for 6-11 GHz and ± 2 dB for 13-38 GHz. For RF-Coupler loss see chapter 5.5.2.

Frequency band: [GHz]	Typical values measured with modulation (PRBS-data). Ref. Point C'. [dBm]										
	L6	U6	7	8	11	13/15	18	23	26	32	38
4xE1@7MHz (QPSK)	+30	+30	+29	+29	+28	+25	+22	+22	+21.5	+21	+20.5
8xE1@7MHz (16State)	+28	+28	+27	+27	+26	+23	+20	+20	+19.5	+19	+18.5
8xE1@14MHz (QPSK)	+30	+30	+29	+29	+28	+25	+22	+22	+21.5	+21	+20.5
16xE1@14MHz (16State)	+28	+28	+27	+27	+26	+23	+20	+20	+19.5	+19	+18.5
16xE1@28MHz (QPSK)	+30	+30	+29	+29	+28	+25	+22	+22	+21.5	+21	+20.5
20xE1@14MHz (16State)	+28	+28	+27	+27	+26	+23	+20	+20	+19.5	+19	+18.5
40xE1@28MHz (16State)	+27	+27	+26	+26	+25	+22	+19	+19	+18.5	+18	+17.5
50xE1@28MHz (32State)	+26	+26	+25	+25	+24	+21	+18	+18	+17.5	+17	+16.5
75xE1@28MHz (128State)	+25	+25	+24	+24	+23	+18	+17	+17	+16.5	+16	+15.5

Table 5-1 Nominal output power

5.1.2. Automatic/Manual Power Control (ATPC/MTPC)

ATPC is an optional feature, which is aimed to drive the TX power amplifier output level from a proper minimum, which is calculated to facilitate the radio network planning and is used in the case of normal propagation, up to a maximum value, which is given in Chapter 3.3.1. When ATPC is disabled (i.e. MTPC mode), the output power can be set by the user.

ATPC-figures:

Transmitter power output regulation speed > 50 dB/s
 ATPC-range 20 dB

Nominal input level is adjustable by the user.

Adjustment range: -30 dBm to -60 dBm

In Hot Standby configuration it is recommended to use simultaneous switching of TX and Rx side within a terminal, when ATPC is enabled.

MTPC figures:

MTPC range: 15 dB¹
 Step size: 0.1 dB
 Accuracy: See output power tolerance in Chapter 5.1.1

¹ For compliance to optional ETSI mask requirement of -60 dBc in frequency bands from 3GHz to 8GHz, the MTPC range is 10 dB.

5.1.3. TX oscillator frequency tolerance

Frequency tolerance: $\leq \pm 10$ ppm.
 The tolerance includes both short-term factors (environmental effects) and long-term ageing effects.

5.2. Receiver Characteristics

Typical values measured with modulation (PRBS-data). Ref. Point C'.
 Guaranteed values are 1.5 dB higher. For RF-Coupler loss see chapter 5.5.2

5.2.1. Receiver Threshold 4xE1 - 7 MHz BW

Frequency band: [GHz]	L6	U6	7	8	11	13/15	18	23	26	32	38
BER \leq 10-6 [dBm]	-91	-91	-91	-91	-90.5	-90	-89	-89	-88.5	-87	-86.5
BER \leq 10-8 [dBm]	-90	-89.5	-89.5	-89.5	-89	-88.5	-87.5	-87.5	-87	-86	-85.5
BER \leq 10-10 [dBm]	-89	-88.5	-88.5	-88.5	-88	87.5	-86.5	-86.5	-86	-85	-84

Table 5-2 Receiver threshold 4xE1 in 7 MHz channel

5.2.2. Receiver Threshold 8xE1 - 7 MHz BW

Frequency band: [GHz]	L6	U6	7	8	11	13/15	18	23	26	32	38
BER \leq 10-6 [dBm]	-85	-85	-85	-85	-84.5	-84	-83	-83	-82.5	-81	-80.5
BER \leq 10-8 [dBm]	-84	-83.5	-83.5	-83.5	-83	-82.5	-81.5	-81.5	-81	-80	-79
BER \leq 10-10 [dBm]	-82	-82	-82	-82	-81.5	-81	-80	-80	-79.5	78.5	-77.5

Table 5-3 Receiver threshold 8xE1 in 7 MHz channel

5.2.3. Receiver Threshold 8xE1 - 14 MHz BW

Frequency band: [GHz]	L6	U6	7	8	11	13/15	18	23	26	32	38
BER \leq 10-6 [dBm]	-87.5	-87.5	-87.5	-87.5	-87	-86.5	-85.5	-85.5	-85	-83.5	-83
BER \leq 10-8 [dBm]	-86.5	-86	-86	-86	-85.5	-85	-84	-84	-83.5	-82.5	-82
BER \leq 10-10 [dBm]	-85	-85	-85	-85	-84.5	-84	-83	-83	-82.5	-81.5	-81

Table 5-4 Receiver threshold 8xE1 in 14 MHz channel

5.2.4. Receiver Threshold 16xE1 - 14 MHz BW

Frequency band: [GHz]	L6	U6	7	8	11	13/15	18	23	26	32	38
BER ≤ 10 ⁻⁶ [dBm]	-81.5	-81.5	-81.5	-81.5	-81	-80.5	-79.5	-79.5	-79	-77.5	-77
BER ≤ 10 ⁻⁸ [dBm]	-80.5	-80	-80	-80	-79.5	-79	-78	-78	-77.5	76.5	-76
BER ≤ 10 ⁻¹⁰ [dBm]	-79	-78.5	-78.5	-78.5	-78	-77.5	76.5	76.5	-76	-75	-74.5

Table 5-5 Receiver threshold 16xE1 in 14 MHz channel

5.2.5. Receiver Threshold 16xE1 - 28 MHz BW

Frequency band: [GHz]	L6	U6	7	8	11	13/15	18	23	26	32	38
BER ≤ 10 ⁻⁶ [dBm]	-85	-85	-85	-85	-84.5	-84	-83	-83	-82.5	-81	-80.5
BER ≤ 10 ⁻⁸ [dBm]	-84	-83.5	-83.5	-83.5	-83	-82.5	-81.5	-81.5	-81	-80	-79
BER ≤ 10 ⁻¹⁰ [dBm]	-82.5	-82.5	-82.5	-82.5	-82	-81.5	-80.5	-80.5	-80	-79	-78

Table 5-6 Receiver threshold 16xE1 in 28 MHz channel

5.2.6. Receiver Threshold 20xE1 - 14 MHz BW

Frequency band: [GHz]	L6	U6	7	8	11	13/15	18	23	26	32	38
BER ≤ 10 ⁻⁶ [dBm]	-80.5	-80.5	-80.5	-80.5	-80	-79.5	-78.5	-78.5	-78	-77	-76
BER ≤ 10 ⁻⁸ [dBm]	-79.5	-79.5	-79.5	-79.5	-79	-78.5	-77.5	-77.5	-77	-75.5	-75
BER ≤ 10 ⁻¹⁰ [dBm]	-78.5	-78	-78	-78	-77.5	-77	-76.5	-76.5	-75.5	-74.5	-74

Table 5-7 Receiver threshold 20xE1 in 14 MHz channel

5.2.7. Receiver Threshold 40xE1 - 28 MHz BW

Frequency band: [GHz]	L6	U6	7	8	11	13/15	18	23	26	32	38
BER ≤ 10 ⁻⁶ [dBm]	-78.5	-78	-78	-78	-77.5	-77	-76.5	-76.5	-75.5	-74.5	-74
BER ≤ 10 ⁻⁸ [dBm]	-76.5	-76.5	-76.5	-76.5	-76	-75.5	-74.5	-74.5	-74	-73	-72
BER ≤ 10 ⁻¹⁰ [dBm]	-75	-75	-75	-75	-74.5	-74	-73	-73	-72.5	-71	-70.5

Table 5-8 Receiver threshold 40xE1 in 28 MHz channel

5.2.8. Receiver Threshold 50xE1 - 28 MHz BW

Frequency band: [GHz]	L6	U6	7	8	11	13/15	18	23	26	32	38
BER ≤ 10 ⁻⁶ [dBm]	-77.5	-77	-77	-77	-76.5	-76	-75	-75	-74.5	-73.5	-73
BER ≤ 10 ⁻⁸ [dBm]	-76	-76	-76	-76	-75.5	-75	-74	-74	-73.5	-72	-71.5
BER ≤ 10 ⁻¹⁰ [dBm]	-75	-75	-75	-75	-74.5	-74	-73	-73	-72.5	-71	-70.5

Table 5-9 Receiver threshold 50xE1 in 28 MHz channel

5.2.9. Receiver Threshold 75xE1 - 28 MHz BW

Frequency band: [GHz]	L6	U6	7	8	11	13/15	18	23	26	32	38
BER ≤ 10 ⁻⁶ [dBm]	-71	-71	-71	-71	-70.5	-70	-69	-69	-68.5	-67	-66.5
BER ≤ 10 ⁻⁸ [dBm]	-69.5	-69.5	-69.5	-69.5	-69	-68.5	-67.5	-67.5	-67	-65.5	-65
BER ≤ 10 ⁻¹⁰ [dBm]	-68	-68	-68	-68	-67.5	-67	-66	-66	-65.5	-64.5	-63.5

Table 5-10 Receiver threshold 75xE1 in 28 MHz channel

5.2.10. Maximum input level

Maximum input signal levels in point C (measured with PRBS of 2²³-1).

These limits apply without interference:

Frequency band: [GHz]	6-18	23-38
BER ≤ 10 ⁻⁶ [dBm]	-17	-20
BER ≤ 10 ⁻⁸ [dBm]	-19	-22
BER ≤ 10 ⁻¹⁰ [dBm]	-21	-24

Table 5-11 Maximum input signal level

5.2.11. RX oscillator frequency tolerance

Frequency tolerance:

≤ ±10 ppm

This limit includes both short-term factors (environmental effects) and long-term ageing effects.

5.2.12. Noise Figure

Ref. Point C. Guaranteed Values.

Frequency band: [GHz]	6-8	11	13/15	18/23	26	28	31/32	38
Noise figure F [dB]	≤ 3.9	≤ 4.4	≤ 4.8	≤ 5.8	≤ 6.3	≤ 7.3	≤ 7.4	≤ 7.9

5.3. Interference sensitivity

5.3.1. Co-channel interference sensitivity

The limits of the co-channel interference sensitivity are shown in Table 5-12, referred to point C. The table shows maximum and typical C/I values for 1 dB and 3 dB increase of the 10^{-6} BER threshold.

System	Maximum C/I at BER = 10^{-6} @ RSL Degradation [dB]		Typical C/I at BER = 10^{-6} @ RSL Degradation [dB]	
	1 dB degr.	3 dB degr.	3 dB degr.	3 dB degr.
Capacity and Channel BW				
4xE1@7MHz (QPSK)	23	19	18	14
8xE1@7MHz (16State)	30	26.5	24	20
8xE1@14MHz (QPSK)	23	19	18	14
16xE1@14MHz (16State)	30	26.5	24	20
16xE1@28MHz (QPSK)	23	19	18	14
20xE1@14MHz (16State)	30	26.5	25	21
40xE1@28MHz (16State)	30	26.5	24	20
50xE1@28MHz (32State)	30	26.5	25	21
75xE1@28MHz (128State)	31.5	27.5	31	27

Table 5-12 Co-Channel Interference Sensitivity

5.3.2. Adjacent channel interference sensitivity

The limits of the adjacent channel interference sensitivity are as given in Table 5-13 Adjacent Channel Interference Sensitivity

, referred to point C. The tables show maximum C/I values for 1 dB and 3 dB increase of the 10^{-6} BER threshold.

System	Maximum C/I at BER = 10^{-6} @ RSL Degradation [dB]		Typical C/I at BER = 10^{-6} @ RSL Degradation [dB]	
	1 dB degr.	3 dB degr.	1 dB degr.	3 dB degr.
Capacity and Channel BW				
4xE1@7MHz (QPSK)	0	-4	TBD	TBD
8xE1@7MHz (16State)	-1	-5	TBD	TBD
8xE1@14MHz (QPSK)	0	-4	TBD	TBD
16xE1@14MHz (16State)	-1	-5	TBD	TBD
16xE1@28MHz (QPSK)	0	-4	TBD	TBD
20xE1@14MHz (16State)	-2	-5	TBD	TBD
40xE1@28MHz (16State)	-3.5	-7.5	TBD	TBD
50xE1@28MHz (32State)	-6	-9.5	TBD	TBD
75xE1@28MHz (128State)	3	-1	TBD	TBD

Table 5-13 Adjacent Channel Interference Sensitivity

5.4. System Performance

5.4.1. System Gain

For RF-Coupler loss see chapter 5.5.2.

System Capacity / Frequency band: [GHz]	Typical values @ BER 10 ⁻⁶ - ref point C'C [dB]										
	L6	U6	7	8	11	13/15	18	23	26	32	38
4xE1@7MHz (QPSK)	121	121	120	120	118.5	115	111	111	110	109	107
8xE1@7MHz (16State)	113	113	112	112	110.5	107	103	103	102	100	99
8xE1@14MHz (QPSK)	117.5	117.5	116.5	116.5	115	111.5	107.5	107.5	106.5	104.5	103.5
16xE1@14MHz (16State)	109.5	109.5	108.5	108.5	107	103.5	99.5	99.5	98.5	96.5	95.5
16xE1@28MHz (QPSK)	115	115	114	114	112.5	109	105	105	104	102	101
20xE1@14MHz (16State)	108.5	108.5	107.5	107.5	106	102.5	98.5	98.5	97.5	96	94.5
40xE1@28MHz (16State)	105.5	105	104	104	102.5	99	95.5	95.5	94	92.5	91.5
50xE1@28MHz (32State)	103.5	103	102	102	100.5	97	93	93	92	90.5	89.5
75xE1@28MHz (128State)	96	96	95	95	93.5	88	86	86	85	83	82

Table 5-14 System gain

5.4.2. Equipment background BER (Residual BER)

Typical residual BER is $\leq 10^{-14}$.

5.4.3. System Signature

The equipment includes an Adaptive Time Domain Equaliser (ATDE). The system signature is specified below for 6.3 ns delay. The limits are valid for both minimum and non-minimum phase.

Channel Bandwidth	28 MHz	14 MHz	7 MHz
Max. notch depth, minimum and non-minimum phase [dB]	24	24	24
Signature bandwidth [MHz]	28	14	7
Signature factor, typical value	1.2	TBD	TBD
Dispersive Fading Margin (Bellcore), typical value [dB]	52	TBD	TBD

Table 5-15 Typical signature values

5.5. Diplexer and Antenna Interface

5.5.1. General description

The diplexer determines the ODU sub-band coverage and duplex spacing. Most frequency bands are divided into only two sub-bands. See APPENDIX 1 for details. ODU transmit and receive frequency can be set to any frequency within the given pass-band range.

5.5.2. RF-Coupler

The additional loss for RF-Coupler is given in Table 5-16. The RF-Coupler is used in protected configurations and single polarised 2+0 systems.

	Symmetrical RF-Coupler		Asymmetrical RF-Coupler			
			Main		Protection	
	Nom	Max	Nom	Max	Nom	Max
Transmission loss [dB] Tx or Rx	3.4	3.8	1.5	2	6.5	7

Table 5-16 RF-Coupler loss

5.5.3. Interface to Antenna feeder system – non integrated antennas

The interface between the ODU-Diplexer (1+0 configuration) or HSB-coupler (HSB configuration) and the antenna feeder system is rectangular waveguide. The ODU-Diplexer and HSB-coupler flange types and corresponding waveguides to be used (if remote mount) is shown in Table 5-17. The ODU-Diplexer and HSB-coupler aluminium flanges are protected by chromate coating.



Frequency band [GHz]	L6/U6	7/8	11	13	15	18/23/26	32/38
Waveguide (remote mount)	R70 / WR137	R84 / WR112	R100 / WR90	R120 / WR75	R140 / WR62	R220 / WR42	R320 / WR28
ODU-Diplexer and HSB-Coupler Flange types	PDR70	CBR84	CBR100	CBR120	CBR140	CBR220	CBR320
							

Table 5-17 ODU flanges and waveguide

5.6. IFU-ODU Interface

5.6.1. Cable interface characteristics

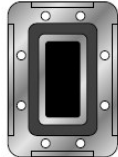
The following signals are transmitted via the cable:

- Transmit and Receive data signal.
- Power to the ODU.
- IFU - ODU Communication (IO-Com) for configuration and control of the ODU.

The cable interface has over-voltage, over-current and reverse polarity protection.

The equipment compensates automatically for different cable lengths.

5.6.2. Cable characteristics

The cable must be in accordance with the following requirements:

Characteristic impedance:	50 ± 3 Ω
Maximum attenuation at 47 MHz:	9 dB
Maximum attenuation at 140 MHz:	18 dB
Maximum attenuation at 373 MHz:	30 dB
Maximum cable length:	300 m
Connector:	TNC, male

Recommended cables and maximum lengths at 40.5 Volt:

Cable 50Ω	Maximum cable length with minimum supply voltage. (40.5 volt)
Cinta CNT 400 (1/4") (Andrew)	200
Heliac LDF1-50. (1/4") (Andrew)	200
Cellflex LCF 14-50J(1/4") (RFS)	200
Heliac LDF2-50. (3/8") (Andrew)	300
Cellflex LCF 38-50J (3/8") (RFS)	300

Table 5-18 Cable lengths, IFU-ODU cable

5.7. Radio Protection Switching (RPS)

5.7.1. Specification of the protection switching system

In order to facilitate switching without introducing bit-errors, a hitless switching system is provided. The Radio Protection Switching function is used in HSB and 1+1 Frequency Diversity configurations. Automatic and manual switching is available. The manual switching can be hitless or forced and is performed from the Element Manager. In Hot Standby configurations the TX- and RX- switching at a terminal normally operates independently, but they may be configured to operate together.

5.7.2. Switching criteria and switching operation time, Rx

Alarm	Switch time	Configurable
EW (Early Warning)	*	Yes
LBER (Light degradation)	*	Yes
HBER (Significant degradation)	5 ms	Yes
Low RF Input level	5 ms	Yes
Sync loss OOF	5 ms	No
Rx Alarm IFU (LOF, LOC)	5 ms	No

The thresholds for the BER criteria, HBER, LBER and Early Warning (EW), are configurable.

* Depending on alarm detection time.

5.7.3. Switching criteria and switching operation time, Tx

Alarm	Switch time
LIU TX Alarm	50 ms
IFU Basic Frame TX Alarm	50 ms
RIU TX Alarm	50 ms
Radio TX Alarm (ODU)	50 ms

6. BASEBAND CHARACTERISTICS

The E1/T1 signals and Ethernet traffic are mapped in to a scalable frame for transport towards the ODU. This frame has in addition to the main traffic two 64 kb/s service channels for user traffic. Ethernet traffic is scaleable in steps of E1s or T1s.

6.1. User Interfaces

The IFU can be equipped with the following interface units:

- 12xE1 and 25xE1
- 8xT1 and 16xT1
- 64 kb/s Serial Channel Unit
- EOW Unit (Service channel)
- Alarm and Control Unit
- SDH/SONET DXC Unit
- 155 Mb/s electrical or optical interface

6.2. Ethernet functionality

6.2.1. General

One of the Ethernet ports at the SU is used for user traffic. The interface is 10/100BASE-TX. The Ethernet traffic can be mixed with TDM traffic and is scaleable in steps of E1s or T1s.

6.2.2. Ethernet Traffic Mapping

Ethernet traffic is mapped into E1s or T1s using a proprietary method.

6.2.3. Flow Control

Ethernet Flow Control can be enabled/disabled.

6.2.4. MAC learning

MAC-learning can be enabled/disabled. MAC-table aging is configurable.

6.2.5. Link-Loss Failure pass through on the Ethernet port

Evolution Series supports a Link-Loss Failure pass through, LLF. This is useful for routers or switches to detect that the Ethernet connection has failed or there is no pass through connection through the radio link side. The LLF function is based on the principle that the interface on the opposite side will be disconnected when the link on the Ethernet port or the radio link has failed. Hence, a failure situation will be communicated to either ends in the link configuration.

When there is a radio link failure, the LLF function will control the Ethernet link on the opposite side of the radio link by the link status on each side. I.e. if the incoming Ethernet signal on one side is disconnected, the output on the Ethernet port on the opposite side will be turned off.

6.3. Transmission Interfaces

6.3.1. Interface characteristics 1.5 Mbit/s

Electrical interface according to ANSI T1.102-1993 and ITU-T Rec. G.703:

Bitrate:	1.544 Mbit/s \pm 32 ppm
Line code:	B8ZS
Impedance:	100 Ω balanced.
Line Build Out [feet]:	0-133, 133-266, 266-399, 399-533, & 533-655
Connector type wayside:	RJ-45/RJ48C
Connector type tributaries:	50 pin multiconnector

6.3.2. Interface characteristics 2 Mbit/s

Interface parameters according to ITU-T Rec. G.703:

Bitrate:	2.048 Mbit/s \pm 50 ppm
Line code:	HDB3
Impedance:	120 Ω balanced
Maximum attenuation of input signal at 1.024 MHz:	6 dB
Connector type wayside:	RJ-45/RJ48C
Connector type tributaries:	50 pin multiconnector

6.3.3. Interface characteristics 155 Mbit/s electrical

Electrical interface according to ITU-T Rec. G.703:

Bitrate:	155.520 Mbit/s \pm 20 ppm
Line code:	CMI
Impedance:	75 Ω unbalanced
Maximum attenuation of input signal at 78 MHz:	12.7 dB
Connector type:	DIN47297, 1.0/2.3mm, dual (IEC 60169-29)

6.3.4. Interface characteristics 155 Mbit/s optical - Intermediate Reach

Optical interface based on **single mode** fibre (G.652 – single mode).

According to ITU-T Rec. G.957; S-1.1 and ANSI: T1.105.06; IR-1

Approximate reach: 15 km

Bitrate:	155.520 Mbit/s \pm 20 ppm
Operating wavelength range:	1261 - 1360 nm
Source type:	MLM
Mean launched power: - Maximum:	-8 dBm
- Minimum:	-15 dBm
Minimum receiver sensitivity (BER < 10 ⁻¹⁰):	-28 dBm
Minimum receiver overload:	-8 dBm
Connector type:	LC Duplex

6.3.5. Interface characteristics 155 Mbit/s optical - Long Reach 1300nm

Optical interface based on **single mode** fibre (G.652 – single mode). Approximate reach: 40 km
According to ITU-T Rec. G.957; L-1.1 and ANSI: T1.105.06-1996; LR-1

Bitrate:	155.520 Mbit/s \pm 20 ppm
Operating wavelength range:	1263 - 1360 nm
Source type:	MLM
Mean launched power: - Maximum:	0 dBm
- Minimum:	-5dBm
Minimum receiver sensitivity (BER < 10 ⁻¹⁰):	- 34 dBm
Minimum receiver overload:	-10 dBm
Connector type:	LC Duplex

6.3.6. Interface characteristics 155 Mbit/s optical - Long Reach 1500nm

Optical interface based on **single mode** fibre (G.652 – single mode). Approximate reach: 80 km
According to ITU-T Rec. G.957; L-1.2 and ANSI: T1.105.06-1996; LR-2

Bitrate:	155.520 Mbit/s \pm 20 ppm
Operating wavelength range:	1480 - 1580 nm
Source type:	SLM
Mean launched power: - Maximum:	0 dBm
- Minimum:	-5dBm
Minimum receiver sensitivity (BER < 10 ⁻¹⁰):	-34 dBm
Minimum receiver overload:	-10 dBm
Connector type:	LC Duplex

6.3.7. Interface characteristics Ethernet – 10/100 BASE-TX:

Connector type:	RJ-45
Electrical interface:	IEEE 802.3 Full Duplex

The interfaces are configurable by management software:

- Each port can be configurable Auto-Negotiation, 10BASE-T or 100BASE-TX, half or full duplex.
- Flow control for full duplex connection according to IEEE 802.3x.

6.4. Auxiliary interfaces

6.4.1. 64 kb/s channel characteristics

Two 64kb/s user channels are available.

Interface alternatives:

- Two 64kb/s according to ITU-T G.703, Co-directional timing or
- One 64kb/s according to ITU-T G.703, Contra-directional timing and one 64kb/s according to ITU-T V.11, Contra-directional timing without byte timing

Connector type: RJ-45

6.4.2. Service telephone/Orderwire interfaces

The unit has four RJ-45 connectors, one for handset and three for analogue connections (east/west bridging).

Telephone connector type: RJ-45 (IEC 60603-7)

The performance of the service telephone complies in general with ITU-T Rec. G.712:

- Code: PCM
- Signalling: DTMF according to ITU-T Rec. Q.23
- Frequency range: 0.3 – 3.4 kHz
- Impedance: 600 Ω

The unit has three 4-wire analogue interfaces for connection to other service channel equipment:

OE1 and OE2 Interfaces:

- Not Galvanic Isolated.
- Input/output level: -6 dBm

4 Wire Interface:

- Galvanic Isolated
- Input/output level: 4 dBm, 0 dBm -6 dBm (Nominal) and -10 dBm.

The EOW is transported in one of the two available 64 kb/s channels.

6.4.3. Alarm and Control Unit

The unit has four RJ45 connectors.

Transient protection: Amplitude: < 100 V
Transient protection: Duration: < 10 ms, non-repetitive

External alarm input interfaces:

Number: Eight two-pin interfaces. Galvanic isolated.
Interface: Current loop
State on: > 3.0 mA
State off: < 1.0 mA

Relay output interfaces:

Number: Four two-pin outputs.
Contact Ratings
Inductive Load: 0.5A at 24V DC
0.1A at 110V DC
Resistive Load: 0.8A at 24V DC
0.1A at 110V DC

Analogue Input Interfaces:

Number: Seven single ended inputs, common analogue ground. Not galvanic isolated.
4 inputs: Voltage Range: 0-20V DC
Impedance >100k ohm
2 inputs: Voltage Range: 18-65V DC
Impedance >100k ohm
1 input: Current Range: 0-50 mA
Impedance 50ohm

7. MANAGEMENT SYSTEM CHARACTERISTICS

7.1. General

The powerful integrated supervisory system of Evolution Series provides user-access to the NEs in a most dynamic manner. The management function in the NE can be accessed by the use of a web-browser, Command Line Interface (CLI) or by a SNMP manager such as the NERAs management systems NetMaster EM/NMS.

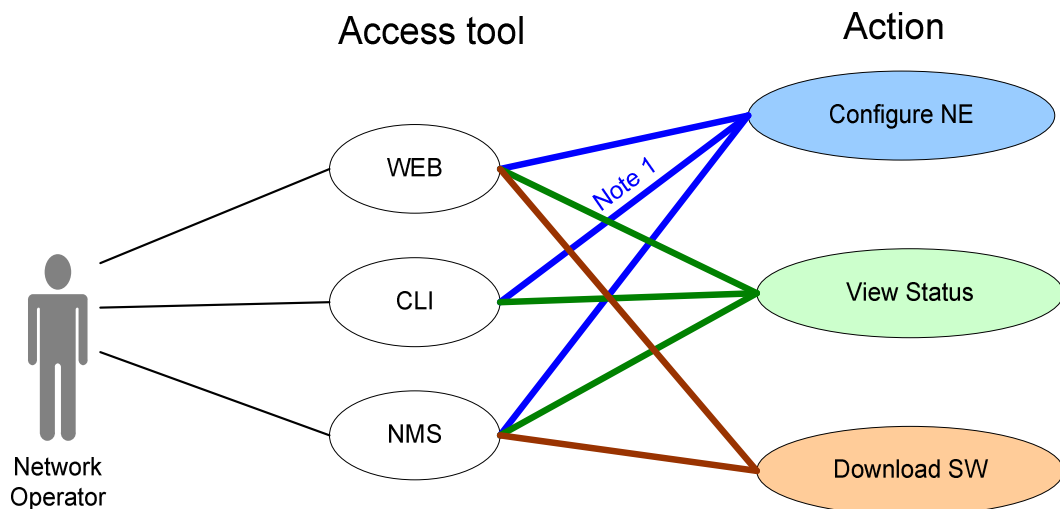

Note 1: Configuration from CLI is limited.

A NE is controlling all the units connected to a specific node with a common supervisory unit. The NE software performs the following management tasks:

Fault management:	Collecting and logging of alarms and analogue measurements from the management units connected to the Node.
Performance management:	Collecting and logging quality measurements according to standards (G.784)
Configuration management:	Configuration of node (including configuration up/download) and Software download
Security management:	Configuration of user id/password and the users privileges in the NE. Includes logging in NE of user actions.

7.1.1. Event logging

Evolution Series NEs can log events and faults in the local fault log. The log size is 10.000 events. The log can be set to wrap-around or halt when it is full. Alarm logging can be masked based on severity level. An operator (with administrator privileges) can also clear the log.

7.1.2. Monitoring of system performance

Transmission performance data is monitored continuously by the built-in supervision function. The supervision function performs measurements and calculations based on the parity bits in each E1/T1. Traffic bit error rate information from the modem is also available.

7.1.2.1. System performance calculations

Performance is based on measuring the error-rate on individual E1 or T1. The following system quality calculations are included:

- Error Second Ratio (ESR)
- Severely Error Second Ratio (SESR)
- Background Block Error Ratio (BBER)
- Unavailable state (UAS)

7.1.2.2. Performance record logging

Performance logging can be activated for one E1/T1 at a time. 15-min, 24-hour and month records are calculated. The log contains the current and last month, current and last 24-hour and current and the sixteen last 15-min records. Threshold values can be defined each of the performance records and a performance alarm will be raised if the threshold is exceeded for any of the periods.

In addition cumulative error counters for parity pulses are available. The operator can read and reset the counters.

7.1.3. Security management

The user must have a username and password defined in the NE in order to log in. Each user name is defined with access privileges. Four levels are defined;

User level	Privileges
------------	------------

Passive Users	Passive users are only able to monitor data. They are not able to change any configuration.
----------------------	---

Active Users	Same as Passive. In addition active users are able to reset counters.
---------------------	---

Master Users	Master users have access to all commands, except those related to user account administration and Configuration/SW download.
---------------------	--

Admin Users	Admin users have access to all commands. The Admin user is the administrator and is responsible for adding, deleting and managing user accounts and privileges. In addition the admin user is responsible for Configuration/SW download.
--------------------	--

7.1.3.1. Security event logging

The NE can log events related to security. The log size is 1000 events. When it is full it will wrap-around. The operator (with administrator privileges) can also clear the log.

7.2. ECC (Embedded Communication Channel)

For communication over a link the ECC channel in the radio-frame is used. The capacity of the ECC channel is 256 kb/s.

7.2.1. IP Routing

The Supervisory system contains a routing function that enables routing of TCP/IP and UDP/IP traffic between the various management interfaces such as the Ethernet interface and the ECC channel. The routing protocol used is OSPF/RIP2. This enables both transport of Evolution Series management traffic as well as other telecom equipment IP based management protocols.

7.2.2. Embedded SNMP agent

The embedded SNMP agent supports the following management functions.

- **Basic monitoring of network and interface parameters**
- **Fault Management**
Supports enumeration of possible alarms, current alarm table and historic alarms (log).
- **Analogue measurements**
Received signal level.
- **Performance measurements**

7.3. Interfaces to the supervision system

7.3.1. General

Four external interfaces are available for the supervision system.

LAN interface	Two 10/100BASE-TX interfaces, IEEE 802.3 Full Duplex. Connector type: RJ-45
USB interface	Two USB ports are available, one host and one device. The host port serves as LCT interface.

7.3.2. LEDs

All IFU units have a LED indicating power on and alarm status.

Colour:	Indication:
Continuous green :	Power on, normal operation
Continuous red	Alarm on unit
Slow blinking red	Unit is receiving configuration
Fast blinking red	Units is not configured or is placed in a wrong IFU slot

Table 7-1 LED status indications

8. REFERENCES

Document code:	Title/Description:
ETSI EN 301 489-4 V1.4.1 (2002-08)	Electromagnetic compatibility and Radio spectrum Matters (ERM); Electro Magnetic Compatibility (EMC) standard for radio equipment and services; Part 4: Specific conditions for fixed radio links and ancillary equipment and services. For grade B equipment
ETSI EN 300 019-1-1 V2.1.4 (2003-04)	Classification of environmental conditions; Storage. Class 1.2, weather protected
ETSI EN 300 019-1-2 V2.1.4 (2003-04)	Classification of environmental conditions; Transportation. Class 2.3, public transportation
ETSI EN 300 019-1-3 V2.1.2 (2003-04)	Classification of environmental conditions; Stationary use at weather protected locations. Class 3.2, partly temperature controlled locations
ETSI EN 300 019-1-4 V2.1.2 (2003-04)	Classification of environmental conditions; Stationary use at non-weather protected locations
ETSI EN 300 132-2 V2.1.2 (2003-09)	Equipment Engineering (EE); Power supply interface at the input to telecommunication equipment; Part 1: Interface operated by Direct Current (DC)
ETSI EN 302 217-1 V1.1.1 (2004-12)	Overview and system-independent common characteristics
ETSI EN 302 217-2-1 V1.1.1 (2004-12)	System-dependent requirements for digital systems operating in frequency bands where frequency co-ordination is applied
ETSI EN 302 217-2-2 V1.1.1 (2004-12)	Harmonized EN covering essential requirements of Article 3.2 of R&TTE Directive for digital systems operating in frequency bands where frequency co-ordination is applied
CENELEC EN 60950: 2000	Safety of information technology equipment
CENELEC EN 60215: 1989	Safety requirements for radio transmitting equipment
CENELEC EN 60825-1 1994	Safety of laser products, Part 1: Equipment classification, requirements and user's guide
CENELEC EN 60825-2 2000	Safety of laser products, Part 2: Safety of optical fibre communication systems
ITU-R Rec. F.746-7 (2003)	Radio-frequency channel arrangements for fixed service systems
ITU-R Rec. F.1099-3 (1999)	Radio-frequency channel arrangements for high capacity radio-relay systems operating in the 5 GHz (4 400-5 000 MHz) band
ITU-R Rec. F.383-7 (2001)	Radio-frequency channel arrangements for high capacity radio-relay systems operating in the lower 6 GHz band
ITU-R Rec. F.384-8 (2004-01)	Radio-frequency channel arrangements for medium and high capacity analogue or digital radio-relay systems operating in the upper 6 GHz band
ITU-R Rec. F.385-8 (2005)	Radio-frequency channel arrangements for radio-relay systems operating in the 7 GHz band
ITU-R Rec. F.386-6 (1999-02)	Radio-frequency channel arrangements for medium and high capacity analogue or digital radio-relay systems operating in the 8 GHz band
ITU-R Rec. F.387-9 (2002-05)	Radio-frequency channel arrangements for radio-relay systems operating in the 11 GHz band
ITU-R Rec. F.497-6 (1999)	Radio-frequency channel arrangements for radio-relay systems operating in the 13 GHz frequency band
ITU-R Rec. F.636-3 (1994)	Radio-frequency channel arrangements for radio-relay systems operating in the 15 GHz band
ITU-R Rec. F.595-8 (2003-02)	Radio-frequency channel arrangements for radio-relay systems operating in the 18 GHz band
ITU-R Rec. F.637-3 (1999)	Radio-frequency channel arrangements for radio-relay systems operating in the 23 GHz band
ITU-R Rec. F.748-4 (2001)	Radio-frequency channel arrangements for radio-relay systems operating in the 25, 26, and 28 GHz bands
ITU-R F.1520-2 (2003-02)	Radio-frequency arrangements for systems in the fixed service operating in the band 31.8-33.4 GHz
ITU-R Rec. F.749-2 (2001)	Radio-frequency channel arrangements for radio-relay systems operating in the 38 GHz band
ITU-R Rec. F.750-4 (2000-05)	Architectures and functional aspects of radio-relay systems for synchronous digital hierarchy (SDH)-based network
ITU-T Rec. G.703 (11/2001)	Physical/electrical characteristics of hierarchical digital interfaces
ITU-T Rec. G.823 (03/2000)	The control of jitter and wander within digital networks which are based on the 2048 kbit/s hierarchy
ITU-T Rec. G.825 (03/2000)	The control of jitter and wander within digital networks which are based on the

	synchronous digital hierarchy (SDH).
ITU-T Rec. G.826 (02/1999)	Error performance parameters and objectives for international, constant bit rate digital paths at or above the primary rate
ITU-T Rec. G.828 (03/2000)	Error performance parameters and objectives for international, constant bit rate synchronous digital paths
ITU-T Rec. G.921 (11/1988)	Digital Sections based on the 2048 kbit/s hierarchy.
ITU-T Rec. G.957 (06/1999)	Optical interfaces for equipments and systems relating to the synchronous digital hierarchy
ITU-T Rec. G.958 (11/1994)	Digital line systems based on the synchronous digital hierarchy for use on optical fiber cable
ETSI TR 101 036-1 V1.3.1 (2002-08)	Fixed Radio Systems; Point-to-point equipment; Generic wordings for standards on digital radio systems characteristics; Part 1: General aspects and point-to-point equipment parameters
CEPT/ERC Rec. 74-01 E (2002-10)	Spurious Emissions
CEPT/ERC Rec 14-01 E (1996-08)	Radio-frequency channel arrangements for high capacity analogue and digital radio-relay systems operating in the band 5925 MHz – 6425 MHz
CEPT/ERC Rec 14-02 E (1996-08)	Radio-frequency channel arrangements for medium and high capacity digital radio-relay systems operating in the band 6425 MHz – 7125 MHz
CEPT/ECC Rec 02-06 (2002-08)	Preferred channel arrangement for digital fixed service systems operating in the frequency range 7125-8500 MHz
CEPT/ERC Rec. 12-06 E (1996-12)	Harmonised radio frequency channel arrangements for digital terrestrial fixed systems operating in the band 10.7 – 11.7 GHz
CEPT /ERC/REC 12-02 (1996-08)	Harmonised radio frequency channel arrangements for analogue and digital terrestrial fixed systems operating in the band 12.75 GHz to 13.25 GHz
CEPT/ERC/REC 12-07 E (1996-08)	Harmonised radio frequency channel arrangements for digital terrestrial fixed systems operating in the bands 14.5 - 14.62 GHz paired with 15.23 - 15.35 GHz
CEPT/ERC/REC 12-03 (1996-08)	Harmonised radio frequency channel arrangements for digital terrestrial fixed systems operating in the band 17.7 GHz to 19.7 GHz
CEPT T/R 13-02 (1994-02)	Preferred channel arrangements for fixed services in the range 22.0-29.5 GHz
IEC 297-2	Dimensions of mechanical structures of the 486.6mm (19in) series: Cabinet and pitches of the rack structures”.
IEC 297-3	Dimensions of mechanical structures of the 486.6mm (19in) series: Sub-rack and associated plug in units”.
IEC 60169-16, Ed. 1.0	Radio-frequency connectors. Part 16: R.F. coaxial connectors with inner diameter of outer conductor 7 mm (0.276 in) with screw coupling - Characteristic impedance 50 ohms (75 ohms)
IEC 60169-29, Ed. 1.0	Radio-frequency connectors - Part 29: Miniature r.f. coaxial connectors with screw-, push-pull and snap-on coupling or slide-in rack and panel applications; Characteristic impedance 50 ohms
IEC 60603-7 (1996)	Connectors for electronic equipment - Part 7-1: Detail specification for 8-way, shielded free and fixed connectors with common mating features, with assessed quality
IEC 60835-2-8 (1993-05)	Methods of measurement for equipment used in digital microwave radio transmission systems - Measurements on terrestrial radio-relay systems - Adaptive equalizer.
IEEE 802.3	Carrier Sense Multiple Access with Collision Detection

ANSI/Industry Canada:

Document code:	Title/Description:
Radio Frequency Channel Plans:	
FCC 47 CFR Part 101	Fixed Microwave Services
SRSP – 305.9	Technical Requirements for Line-of-sight Radio Systems Operating in the Fixed Service in the Band 5915 – 6425 MHz
SRSP – 306.4	Technical Requirements for Line-of-sight Radio Systems Operating in the Fixed Service in the Band – 6425 – 6930 MHz
SRSP – 307.1	Technical Requirements for Fixed Line-of-Sight Radio Systems Operating in the Band 7125-7725 MHz
SRSP – 307.7	Technical Requirements for Fixed Line-of-sight Radio Systems Operating in the Band 7725-8275 MHz
SRSP – 310.7	Technical Requirements for Fixed Line-of-sight Radio Systems Operating in the Band 10.7-11.7 GHz
Electromagnetic Compatibility:	
FCC 47CFR Part 15	Radio Frequency Devices (EMC regulations)
Safety:	
CAN/CSA 22.2 No. 60950-00	Safety – Information processing and business equipment
UL 1950	Safety of Information Technology Equipment
SONET:	
ANSI Rec. T1.105	SONET - Basic Description including Multiplex Structure, Rates and Formats
ANSI Rec. T1.105.06-1996	Telecommunications-Synchronous Optical Network (SONET): Physical Layer Specifications
ANSI Rec. T1.646-1995	Broadband ISDN Physical Layer Specification for User Network Interfaces Including DS1/ATM
ANSI T1.102-1993	Digital Hierarchy – Electrical Interfaces*.

9. TERMINOLOGY

Abbreviation:	Description:
ACAP	Adjacent Channel Alternate Polarisation
ACCP	Adjacent Channel Co-Polarisation
ADM	Add/Drop/Multiplex
AIS	Alarm Indication Signal
ALM	External alarm input/output
AP	Alternating Polarisation
ATDE	Adaptive Time Domain Equaliser
ATPC	Automatic Transmitter Power Control
AUX	Auxiliary functions
BER	Bit Error Rate
C/I	Carrier to Interference ratio
CS	Channel Spacing
DCC	Data Communications Channel
DF-SP	Dual Frequency – Single Polarisation
ECC	Embedded Control Channel
EM	Element Manager
EMC	Electro Magnetic Compatibility
EOW	Engineering Order Wire
EW	Early Warning
GFP	Generic Framing Procedure
HBER	High Bit Error Rate
HSB	HotStandBy
IFU	InterFace Unit
LAN	Local Area Network port (10/100BASE-TX Ethernet)
LBER	Low Bit Error Rate
LIU	Line Interface Unit
LCT	Local Craft Terminal
LOF	Loss Of Frame
LOS	Loss Of Signal
MLM	Multi-Longitudinal Mode
MTBF	Mean Time Between Failure
NMS	Network Management System
OC-3	Optical Carrier – level 3 = 155Mbit/s (OC-1 – level 1 = 51.84 Mbit/s)
ODU	OutDoor Unit

Abbreviation:	Description:
OOF	Out Of Frame
PDH	Plesiochronous Digital Hierarchy
PRBS	Pseudo Random Bit Sequence
PXC	PDH-X-Connect
PWR	Power Supply
RIU	Radio Interface Unit
RF	Radio Frequency
ROHS	Restriction on Hazardous Substances
RPS	Radio Protection Switching
RX	Receiver
SERV	Service function (plug-in unit)
SDH	Synchronous Digital Hierarchy
SETS	Synchronous Equipment Timing Source
SF-DP	Single Frequency - Dual Polarisation
SNCP	Sub Network Connection Protection
SNMP	Simple Network Management Protocol
SONET	Synchronous Optical Network
STM-1	Synchronous Transport Module, 1 means the lowest defined data rate = 155.520 Mbit/sec
SU	Supervisory Unit
SVCE	SerVice ChannEl, used to define the voice channel circuit board
TCP/IP	Transmission Control Protocol/Internet Protocol
TX	Transmitter
USB	Universal Serial Bus
WEEE	Waste Electrical & Electronic Equipment
XCVR	Transmitter/Receiver
XIF	XPIC Improvement Factor
XPIC	X-Polar Interference Canceller

APPENDIX 1 – ODU/DIPLEXER SUB-BAND RANGE

The sub-band tuning range in the table is specified with the RF-channel bandwidth as given in the last column. The sub-band range is wider if configured radio channel bandwidth is narrower.

Freq. band [GHz]	Duplex Spacing	Tx. Freq:	Sub-band 1	Sub-band 2	Sub-band 3	RF Channel BW
5.9-6.4	252.04	Low: High:	5945 – 6034 6197 - 6287	6063 - 6154 6315 – 6406		~28 MHz
5.9-6.4	252.04	Low: High:	5930 - 6020 6182 - 6272	6049 - 6138 6301 - 6390		~28 MHz
6.4-7.1	340	Low: High:	6450 - 6580 6790 - 6920	6610 - 6740 6950 - 7080		40 MHz
6.4-7.1	100	Low: High:	6595 6695	6625 6725	6655 6755	30 MHz
7.1-7.4	154,161	Low: High:	7128 - 7184 7289 - 7345	7170 - 7226 7331 - 7387	7205 - 7264 7366 - 7425	~28 MHz
7.1-7.4	175	Low: High:	7128 - 7184 7289 - 7345			~28 MHz
7.1-7.4	196	Low: High:	7121 - 7177 7317 - 7373	7177 - 7233 7373 - 7429		~28 MHz
7.4-7.7	150	Low: High:	7428 - 7484 7589 - 7645			~28 MHz
7.4-7.7	154,161, 182	Low: High:	7428 - 7484 7589 - 7645	7470 - 7526 7631 - 7687	7505 - 7564 7666 – 7725	~28 MHz
7.4-7.7	168	Low: High:	7428 - 7484 7589 - 7645	7470 - 7526 7631 - 7687	7513 - 7569 7681 – 7737	~28 MHz
7.2-7.5	161	Low: High:	7266 - 7321 7427 - 7482	7325 - 7380 7486 – 7542		~28 MHz
7.4-7.9	245	Low: High:	7442 - 7526 7687 – 7771	7554 - 7638 7799 – 7883		~28 MHz
7.1-7.7	300	Low: High:	7139 – 7261 7439 – 7561	7289 - 7411 7289 – 7411		~28 MHz
7.7-8.3	310	Low: High:	7732 - 7837 8039 - 8149	7836 - 7956 8147 – 8267		~28 MHz
7.9-8.4	266	Low: High:	7919 - 8013 8185 - 8279	8031 - 8122 8297 – 8388		~28 MHz
7.9-8.5	310	Low: High:	7919 – 8031 8229 - 8341	8059 - 8171 8369 – 8481		~28 MHz
8.2-8.5	119/126	Low: High:	8287.5 - 8305 8411 - 8427	8330 - 8347 8453 – 8469		~28 MHz
8.2-8.5	154	Low: High:	8217 - 8248 8370 - 8400	8273 - 8307 8428 – 8458	8299- 8330 8452 - 8482	~28 MHz
11	490/530	Low: High:	10735 - 10935 11225 - 11465	10975 - 11175 11465 - 11665		40 MHz
11	530	Low: High:	10715 - 10915 11245 - 11445	10955 - 11155 11485 - 11685		40 MHz
11	490	Low: High:	10725 - 10935 11215 - 11425	10965 - 11175 11455 – 11665		30 MHz
13	266	Low: High:	12765 - 12877 13031 - 13143	12849 – 12963 13115 - 13229		28 MHz
15	490	Low: High:	14417 - 14676 14907 - 15166	14669 - 14914 15117 - 15334		28 MHz
15	420	Low: High:	14515 - 14732 14935 - 15152	14669 - 14914 15117 - 15334		28 MHz

15	644/728	Low: High:	14515 - 14683 15159 - 15334			28 MHz
15	315	Low: High:	14641 - 14781 14956 - 15096	14753 - 14893 15068 - 15208		28 MHz
18	1010	Low: High:	17727.5 - 18193.5 18737.5 - 19202.5	18195 - 18662.5 19205 - 19672.5		55 MHz
18	1560	Low: High:	17727.5 - 18112.5 19287.5 - 19672.5			55 MHz
18	1092.5	Low: High:	17727.5 - 18195 18820 - 19287.5	18112.5 - 18580 19205 - 19672.5		27.5 MHz
18	1120	Low: High:	17742 - 18181 18834 - 19273	18127 - 18566 19219 - 19658		55 MHz
23	1232	Low: High:	21228 - 21772 22428 - 22988	21791 - 22316 23023 - 23548		56 MHz
23	1200	Low: High:	21225 - 21775 22425 - 22991	21825 - 22375 23025 - 23575		50 MHz
23	1008	Low: High:	22031 - 22562 23039 - 23570			56 MHz
26	1008	Low: High:	24577 - 24976 25585 - 25984	24997 - 25417 26005 - 26425		56 MHz
28	1008	Low: High:	27576.5 - 27975.5 28584.5 - 28983.5	27996.5 - 28416.5 29004.5 - 29424.5		56 MHz
32	812	Low: High:	31843 - 32200 32655 - 33012	32218 - 32543 33030 - 33355		56 MHz
38	1260	Low: High:	37086 - 37590 38346 - 38850	37646 - 38150 38906 - 39410		56 MHz
38	700	Low: High:	38625 - 38800 39325 - 39500	38850 - 39025 39550 - 39725	39075 - 39275 39775 - 39975	50 MHz

This page is internationally left blank

This page is intentionally left blank

Nera Networks AS

Kokstadveien 23

PO Box 7090, N-5020 Bergen, Norway

Tel.: +47 55 22 53 00, Fax: +47 55 22 52 99

E-mail: webmaster@nera.no

www.nera.no